



3.3V CMOS 32-BIT BUS TRANSCEIVER WITH 3-STATE OUTPUTS AND BUS-HOLD

IDT74ALVCH32245

FEATURES:

- 0.5 MICRON CMOS Technology
- Typical $t_{sk(o)}$ (Output Skew) < 250ps
- ESD > 2000V per MIL-STD-883, Method 3015; > 200V using machine model (C = 200pF, R = 0)
- $V_{cc} = 3.3V \pm 0.3V$, Normal Range
- $V_{cc} = 2.7V$ to $3.6V$, Extended Range
- $V_{cc} = 2.5V \pm 0.2V$
- CMOS power levels (0.4μ W typ. static)
- Rail-to-Rail output swing for increased noise margin
- Available in 96-ball LFBGA package

DRIVE FEATURES:

- High Output Drivers: $\pm 24mA$
- Suitable for Heavy Loads

APPLICATIONS:

- 3.3V high speed systems
- 3.3V and lower voltage computing systems

DESCRIPTION:

This 32-bit bus transceiver is built using advanced dual metal CMOS technology. This high-speed, low power transceiver is ideal for asynchronous communication between two busses (A and B). The Direction and Output Enable controls are designed to operate the device as either four independent 8-bit transceivers or one 32-bit transceiver. The direction control pins (DIR) control the direction of data flow. The output enable pins (\overline{OE}) override the direction control and disable both ports. All inputs are designed with hysteresis for improved noise margin.

The ALVCH32245 has been designed with a $\pm 24mA$ output driver. This driver is capable of driving a moderate to heavy load while maintaining speed performance.

The ALVCH32245 has "bus-hold" which retains the inputs' last state whenever the input bus goes to a high impedance. This prevents floating inputs and eliminates the need for pull-up/down resistors.

FUNCTIONAL BLOCK DIAGRAM

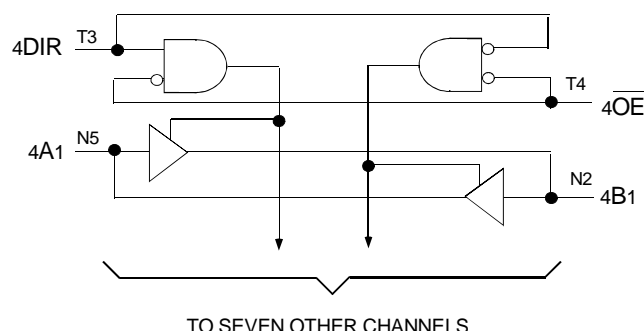
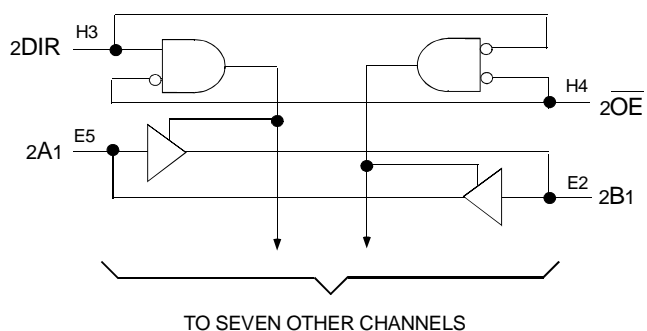
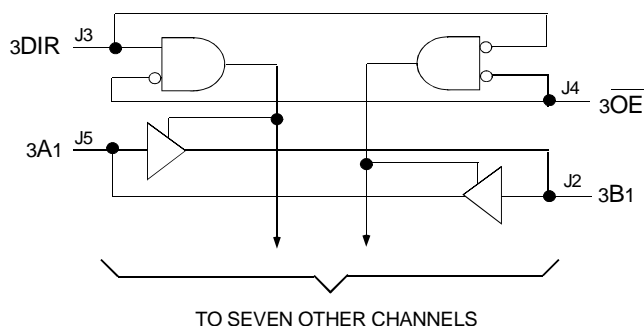
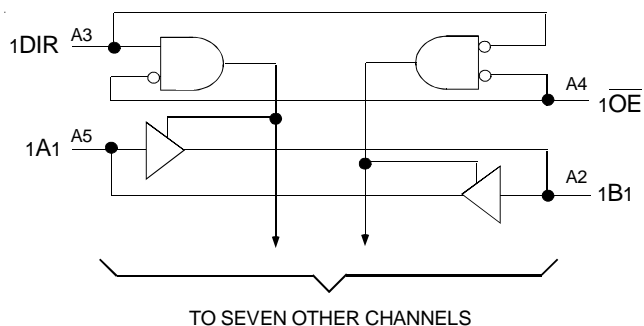

The IDT logo is a registered trademark of Integrated Device Technology, Inc.

INDUSTRIAL TEMPERATURE RANGE

FEBRUARY 2000

PIN CONFIGURATION

6	1A2	1A4	1A6	1A8	2A2	2A4	2A6	2A7	3A2	3A4	3A6	3A8	4A2	4A4	4A6	4A7
5	1A1	1A3	1A5	1A7	2A1	2A3	2A5	2A8	3A1	3A3	3A5	3A7	4A1	4A3	4A5	4A8
4	1 \overline{OE}	GND	VCC	GND	GND	VCC	GND	2 \overline{OE}	3 \overline{OE}	GND	VCC	GND	GND	VCC	GND	4 \overline{OE}
3	1DIR	GND	VCC	GND	GND	VCC	GND	2DIR	3DIR	GND	VCC	GND	GND	VCC	GND	4DIR
2	1B1	1B3	1B5	1B7	2B1	2B3	2B5	2B8	3B1	3B3	3B5	3B7	4B1	4B3	4B5	4B8
1	1B2	1B4	1B6	1B8	2B2	2B4	2B6	2B7	3B2	3B4	3B6	3B8	4B2	4B4	4B6	4B7
	A	B	C	D	E	F	G	H	J	K	L	M	N	P	R	T

LFBGA
TOPVIEW

96 BALL LFBGA PACKAGE ATTRIBUTES

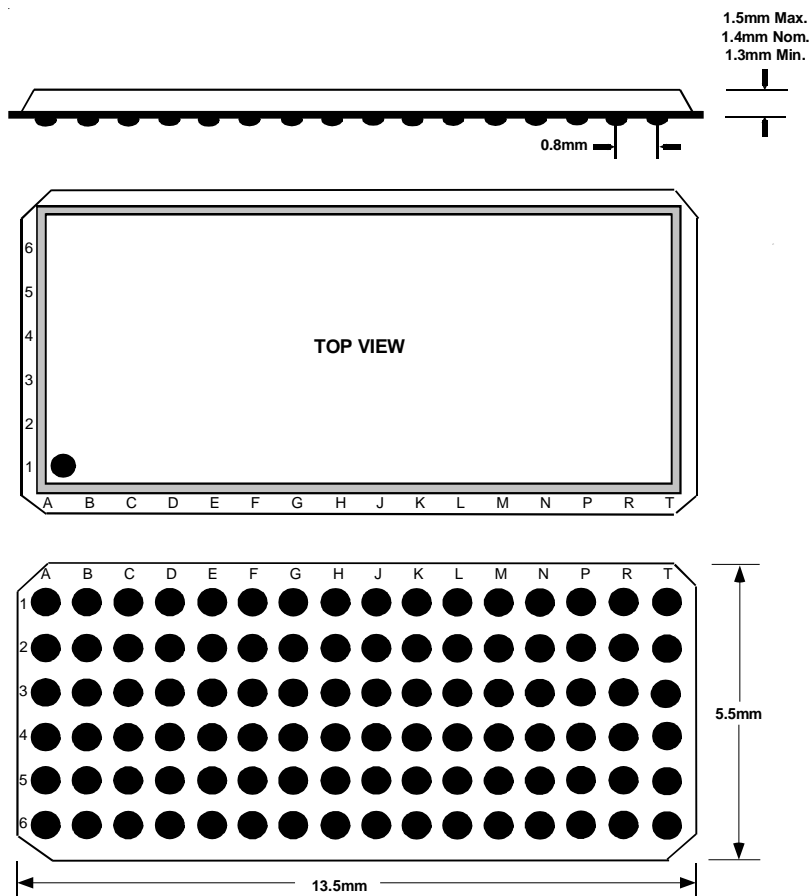

ABSOLUTE MAXIMUM RATINGS⁽¹⁾

Symbol	Description	Max	Unit
V _{TERM} ⁽²⁾	Terminal Voltage with Respect to GND	-0.5 to +4.6	V
V _{TERM} ⁽³⁾	Terminal Voltage with Respect to GND	-0.5 to V _{CC} +0.5	V
T _{STG}	Storage Temperature	-65 to +150	°C
I _{OUT}	DC Output Current	-50 to +50	mA
I _{IK}	Continuous Clamp Current, V _i < 0 or V _i > V _{CC}	±50	mA
I _{OK}	Continuous Clamp Current, V _o < 0	-50	mA
I _{CC} I _{SS}	Continuous Current through each V _{CC} or GND	±100	mA

NOTES:

1. Stresses greater than those listed under ABSOLUTE MAXIMUM RATINGS may cause permanent damage to the device. This is a stress rating only and functional operation of the device at these or any other conditions above those indicated in the operational sections of this specification is not implied. Exposure to absolute maximum rating conditions for extended periods may affect reliability.
2. V_{CC} terminals.
3. All terminals except V_{CC}.

PIN DESCRIPTION

Pin Names	Description
\overline{xOE}	Output Enable Inputs (Active LOW)
xDIR	Direction Control Inputs
xAx	Side A Inputs or 3-State Outputs ⁽¹⁾
xBx	Side B Inputs or 3-State Outputs ⁽¹⁾

NOTE:

1. These pins have "Bus-Hold". All other pins are standard inputs, outputs, or I/Os.

CAPACITANCE (T_A = +25°C, F = 1.0MHz)

Symbol	Parameter ⁽¹⁾	Conditions	Typ.	Max.	Unit
C _{IN}	Input Capacitance	V _{IN} = 0V	5	7	pF
C _{OUT}	Output Capacitance	V _{OUT} = 0V	7	9	pF
C _{I/O}	I/O Port Capacitance	V _{IN} = 0V	7	9	pF

NOTE:

1. As applicable to the device type.

FUNCTION TABLE (EACH 8-BIT SECTION)⁽¹⁾

Inputs		Outputs
x \overline{OE}	xDIR	
L	L	Bus B Data to Bus A
L	H	Bus A Data to Bus B
H	X	High Z State

NOTE:

1. H = HIGH Voltage Level
L = LOW Voltage Level
X = Don't Care
Z = High Impedance

DC ELECTRICAL CHARACTERISTICS OVER OPERATING RANGE

Following Conditions Apply Unless Otherwise Specified:

Operating Condition: $T_A = -40^{\circ}\text{C}$ to $+85^{\circ}\text{C}$

Symbol	Parameter	Test Conditions		Min.	Typ. ⁽¹⁾	Max.	Unit
V _{IH}	Input HIGH Voltage Level	V _{CC} = 2.3V to 2.7V		1.7	—	—	V
		V _{CC} = 2.7V to 3.6V		2	—	—	
V _{IL}	Input LOW Voltage Level	V _{CC} = 2.3V to 2.7V		—	—	0.7	V
		V _{CC} = 2.7V to 3.6V		—	—	0.8	
I _{IH}	Input HIGH Current	V _{CC} = 3.6V	V _I = V _{CC}	—	—	±5	μA
I _{IL}	Input LOW Current	V _{CC} = 3.6V	V _I = GND	—	—	±5	μA
I _{OZH} I _{OZL}	High Impedance Output Current (3-State Output pins)	V _{CC} = 3.6V		—	—	±10	μA
		V _O = GND		—	—	±10	
V _{IK}	Clamp Diode Voltage	V _{CC} = 2.3V, I _{IN} = -18mA		—	-0.7	-1.2	V
V _H	Input Hysteresis	V _{CC} = 3.3V		—	100	—	mV
I _{CC1} I _{CC2} I _{CC3}	Quiescent Power Supply Current	V _{CC} = 3.6V V _{IN} = GND or V _{CC}		—	0.1	40	μA
ΔI _{CC}	Quiescent Power Supply Current Variation	One input at V _{CC} - 0.6V, other inputs at V _{CC} or GND		—	—	750	μA

NOTE:

1. Typical values are at V_{CC} = 3.3V, +25°C ambient.

BUS-HOLD CHARACTERISTICS

Symbol	Parameter ⁽¹⁾	Test Conditions		Min.	Typ. ⁽²⁾	Max.	Unit	
I _{BHH} I _{BHL}	Bus-Hold Input Sustain Current	V _{CC} = 3V		—	—	—	μA	
		V _I = 0.8V		-75	—	—		
I _{BHH} I _{BHL}	Bus-Hold Input Sustain Current	V _{CC} = 2.3V		—	—	—	μA	
		V _I = 0.7V		-45	—	—		
I _{BHHO} I _{BHLO}	Bus-Hold Input Overdrive Current	V _{CC} = 3.6V		V _I = 0 to 3.6V		—	±500	μA

NOTES:

1. Pins with Bus-Hold are identified in the pin description.
2. Typical values are at V_{CC} = 3.3V, +25°C ambient.

OUTPUT DRIVE CHARACTERISTICS

Symbol	Parameter	Test Conditions ⁽¹⁾		Min.	Max.	Unit
VOH	Output HIGH Voltage	VCC = 2.3V to 3.6V	IOH = - 0.1mA	VCC - 0.2	—	V
		VCC = 2.3V	IOH = - 6mA	2	—	
		VCC = 2.3V	IOH = - 12mA	1.7	—	
		VCC = 2.7V		2.2	—	
		VCC = 3V		2.4	—	
		VCC = 3V	IOH = - 24mA	2	—	
VOL	Output LOW Voltage	VCC = 2.3V to 3.6V	IOL = 0.1mA	—	0.2	V
		VCC = 2.3V	IOL = 6mA	—	0.4	
			IOL = 12mA	—	0.7	
		VCC = 2.7V	IOL = 12mA	—	0.4	
		VCC = 3V	IOL = 24mA	—	0.55	

NOTE:
1. VIH and VIL must be within the min. or max. range shown in the DC ELECTRICAL CHARACTERISTICS OVER OPERATING RANGE table for the appropriate VCC range. TA = - 40°C to + 85°C.

OPERATING CHARACTERISTICS, TA = 25°C

Symbol	Parameter	Test Conditions	VCC = 2.5V ± 0.2V	VCC = 3.3V ± 0.3V	Unit
			Typical	Typical	
CPD	Power Dissipation Capacitance per Driver Outputs enabled	CL = 0pF, f = 10Mhz	44	58	pF
CPD	Power Dissipation Capacitance per Driver Outputs disabled		8	10	

SWITCHING CHARACTERISTICS⁽¹⁾

Symbol	Parameter	VCC = 2.5V ± 0.2V		VCC = 2.7V		VCC = 3.3V ± 0.3V		Unit
		Min.	Max.	Min.	Max.	Min.	Max.	
tPLH	Propagation Delay	1	3.7	—	3.6	1	3	ns
tPHL	xAx to xBx or xBx to xAx							
tPZH	Output Enable Time	1	5.7	—	5.4	1	4.4	ns
tPZL	xOE to xAx to xBx							
tPHZ	Output Disable Time	1	5.2	—	4.6	1	4.1	ns
tPLZ	xOE to xAx to xBx							
tSK(O)	Output Skew ⁽²⁾	—	—	—	—	—	500	ps

NOTES:
1. See TEST CIRCUITS AND WAVEFORMS. TA = - 40°C to + 85°C.
2. Skew between any two outputs of the same package and switching in the same direction.

TEST CIRCUITS AND WAVEFORMS

TEST CONDITIONS

Symbol	V _{CC} ⁽¹⁾ =3.3V±0.3V	V _{CC} ⁽¹⁾ =2.7V	V _{CC} ⁽²⁾ =2.5V±0.2V	Unit
V _{LOAD}	6	6	2 x V _{CC}	V
V _{IH}	2.7	2.7	V _{CC}	V
V _T	1.5	1.5	V _{CC} / 2	V
V _{LZ}	300	300	150	mV
V _{HZ}	300	300	150	mV
C _L	50	50	30	pF

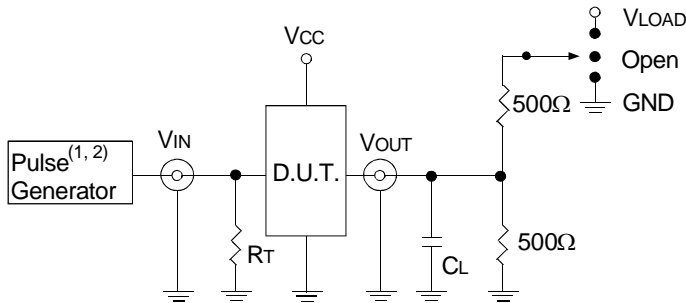

Test Circuit for All Outputs

DEFINITIONS:

C_L = Load capacitance: includes jig and probe capacitance.
R_T = Termination resistance: should be equal to Z_{OUT} of the Pulse Generator.

NOTES:

1. Pulse Generator for All Pulses: Rate ≤ 1.0MHz; t_r ≤ 2.5ns; t_r ≤ 2.5ns.
2. Pulse Generator for All Pulses: Rate ≤ 1.0MHz; t_r ≤ 2ns; t_r ≤ 2ns.

SWITCH POSITION

Test	Switch
Open Drain Disable Low Enable Low	V _{LOAD}
Disable High Enable High	GND
All Other Tests	Open

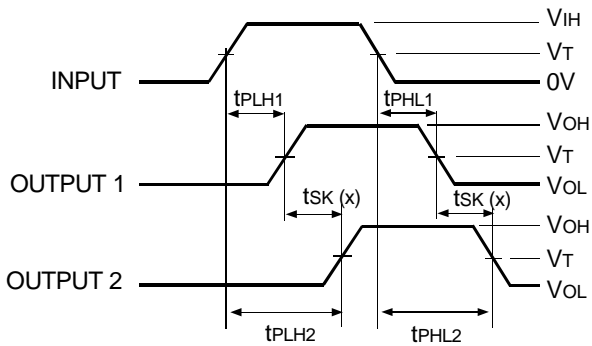

$$tsk(x) = |t_{PLH2} - t_{PLH1}| \text{ or } |t_{PHL2} - t_{PHL1}|$$

Output Skew - tsk(x)

NOTES:

1. For tsk(o) OUTPUT1 and OUTPUT2 are any two outputs.
2. For tsk(b) OUTPUT1 and OUTPUT2 are in the same bank.

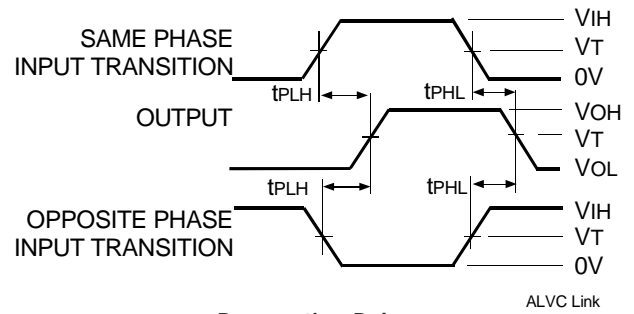

Propagation Delay

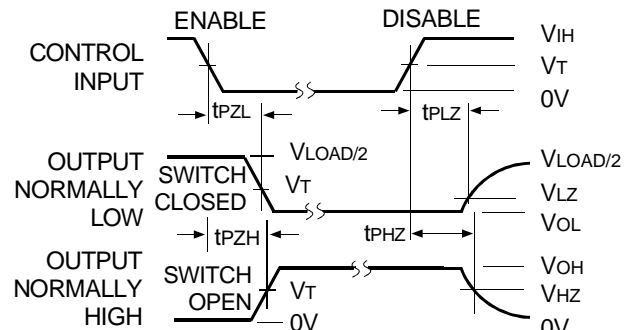

Enable and Disable Times

NOTE:

1. Diagram shown for input Control Enable-LOW and input Control Disable-HIGH.

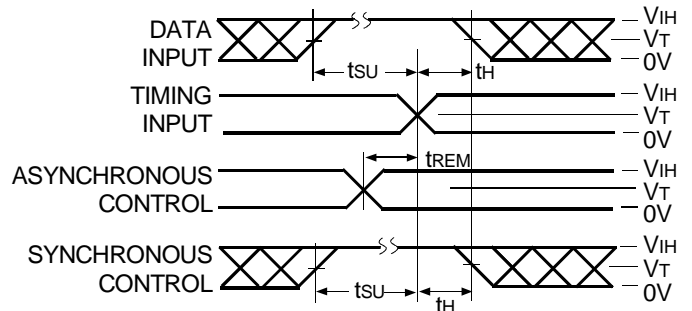

Set-up, Hold, and Release Times

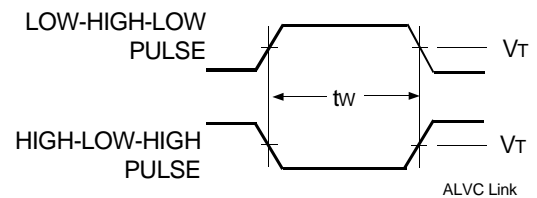

Pulse Width

ORDERING INFORMATION

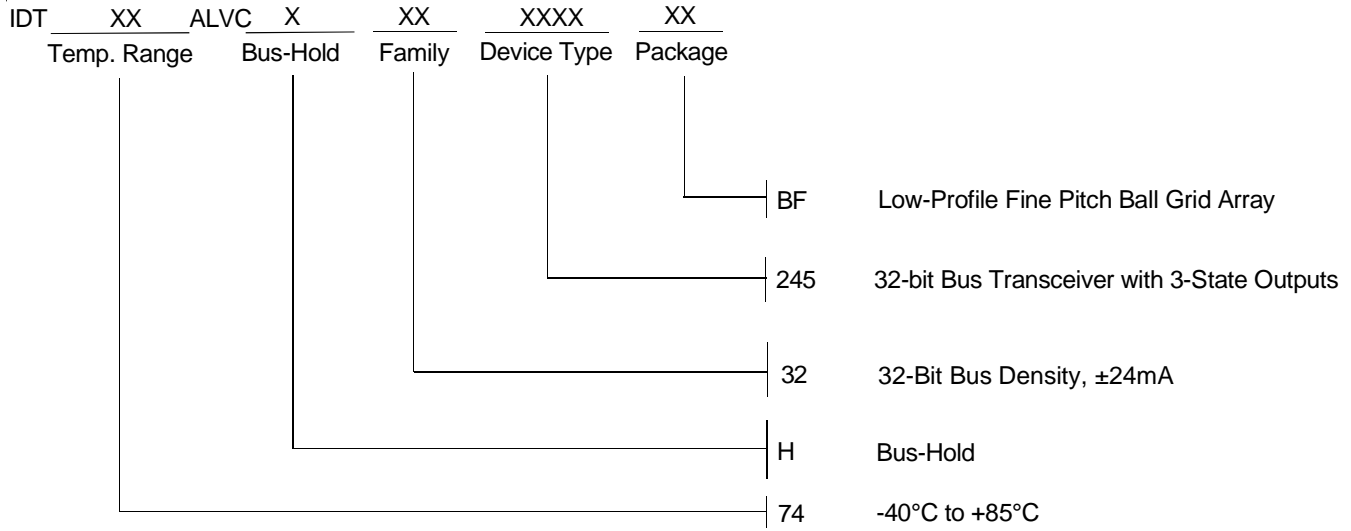

CORPORATE HEADQUARTERS
 2975 Stender Way
 Santa Clara, CA 95054

for SALES:
 800-345-7015 or 408-727-6116
 fax: 408-492-8674
 www.idt.com

for Tech Support:
 logichelp@idt.com
 (408) 654-6459