

# MC10EL07, MC100EL07

## 5V ECL 2-Input XOR/XNOR

The MC10EL/100EL07 is a 2-input XOR/XNOR gate. The device is functionally equivalent to the E107 device with higher performance capabilities. With propagation delays and output transition times significantly faster than the E107, the EL07 is ideally suited for those applications which require the ultimate in AC performance.

The 100 Series contains temperature compensation.

- 260 ps Propagation Delay
- ESD Protection: > 1 KV HBM, > 100 V MM
- PECL Mode Operating Range:  $V_{CC} = 4.2 \text{ V}$  to  $5.7 \text{ V}$  with  $V_{EE} = 0 \text{ V}$
- NECL Mode Operating Range:  $V_{CC} = 0 \text{ V}$  with  $V_{EE} = -4.2 \text{ V}$  to  $-5.7 \text{ V}$
- Internal Input Pulldown Resistors
- Meets or Exceeds JEDEC Spec EIA/JESD78 IC Latchup Test
- Moisture Sensitivity Level 1  
For Additional Information, see Application Note AND8003/D
- Flammability Rating: UL-94 code V-0 @ 1/8", Oxygen Index 28 to 34
- Transistor Count = 47 devices

### LOGIC DIAGRAM AND PINOUT ASSIGNMENT

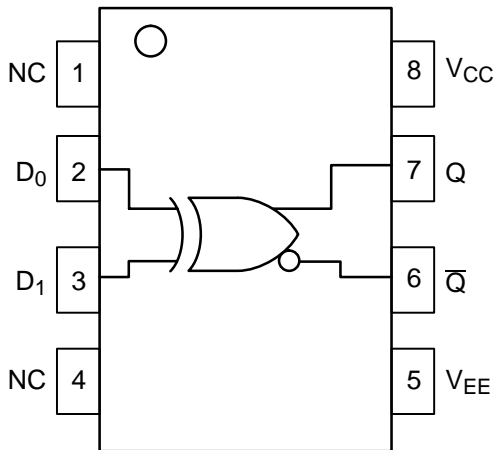

### PIN DESCRIPTION

PIN	FUNCTION
D0, D1	ECL Data Inputs
Q, $\bar{Q}$	ECL Data Outputs
$V_{CC}$	Positive Supply
$V_{EE}$	Negative Supply
NC	No Connect



ON Semiconductor™

<http://onsemi.com>

### MARKING DIAGRAMS\*

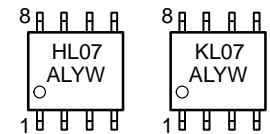
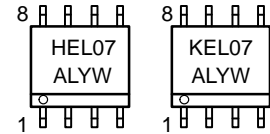
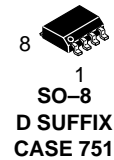

H = MC10                      L = Wafer Lot  
K = MC100                    Y = Year  
A = Assembly Location      W = Work Week

\*For additional information, see Application Note AND8002/D

### ORDERING INFORMATION

Device	Package	Shipping
MC10EL07D	SO-8	98 Units/Rail
MC10EL07DR2	SO-8	2500 Tape & Reel
MC100EL07D	SO-8	98 Units/Rail
MC100EL07DR2	SO-8	2500 Tape & Reel
MC10EL07DT	TSSOP-8	98 Units/Rail
MC10EL07DTR2	TSSOP-8	2500 Tape & Reel
MC100EL07DT	TSSOP-8	98 Units/Rail
MC100EL07DTR2	TSSOP-8	2500 Tape & Reel

# MC10EL07, MC100EL07

## MAXIMUM RATINGS (Note 1.)

Symbol	Parameter	Condition 1	Condition 2	Rating	Units
V <sub>CC</sub>	PECL Mode Power Supply	V <sub>EE</sub> = 0 V		8	V
V <sub>EE</sub>	NECL Mode Power Supply	V <sub>CC</sub> = 0 V		-8	V
V <sub>I</sub>	PECL Mode Input Voltage NECL Mode Input Voltage	V <sub>EE</sub> = 0 V V <sub>CC</sub> = 0 V	V <sub>I</sub> ≤ V <sub>CC</sub> V <sub>I</sub> ≥ V <sub>EE</sub>	6 -6	V V
I <sub>out</sub>	Output Current	Continuous Surge		50 100	mA mA
T <sub>A</sub>	Operating Temperature Range			-40 to +85	°C
T <sub>stg</sub>	Storage Temperature Range			-65 to +150	°C
θ <sub>JA</sub>	Thermal Resistance (Junction to Ambient)	0 LFPM 500 LFPM	8 SOIC 8 SOIC	190 130	°C/W °C/W
θ <sub>JC</sub>	Thermal Resistance (Junction to Case)	std bd	8 SOIC	41 to 44	°C/W
θ <sub>JA</sub>	Thermal Resistance (Junction to Ambient)	0 LFPM 500 LFPM	8 TSSOP 8 TSSOP	185 140	°C/W °C/W
θ <sub>JC</sub>	Thermal Resistance (Junction to Case)	std bd	8 TSSOP	41 to 44 ± 5%	°C/W
T <sub>sol</sub>	Wave Solder	<2 to 3 sec @ 248°C		265	°C

1. Maximum Ratings are those values beyond which device damage may occur.

## 10EL SERIES PECL DC CHARACTERISTICS V<sub>CC</sub>= 5.0 V; V<sub>EE</sub>= 0.0 V (Note 1.)

Symbol	Characteristic	-40°C			25°C			85°C			Unit
		Min	Typ	Max	Min	Typ	Max	Min	Typ	Max	
I <sub>EE</sub>	Power Supply Current		14	17		14	17		14	17	mA
V <sub>OH</sub>	Output HIGH Voltage (Note 2.)	3920	4010	4110	4020	4105	4190	4090	4185	4280	mV
V <sub>OL</sub>	Output LOW Voltage (Note 2.)	3050	3200	3350	3050	3210	3370	3050	3227	3405	mV
V <sub>IH</sub>	Input HIGH Voltage	3770		4110	3870		4190	3940		4280	mV
V <sub>IL</sub>	Input LOW Voltage	3050		3500	3050		3520	3050		3555	mV
I <sub>IH</sub>	Input HIGH Current			250 150			250 150			250 150	μA
I <sub>IL</sub>	Input LOW Current	0.5			0.5			0.3			μA

NOTE: Devices are designed to meet the DC specifications shown in the above table, after thermal equilibrium has been established. The circuit is in a test socket or mounted on a printed circuit board and transverse air flow greater than 500 lfm is maintained.

1. Input and output parameters vary 1:1 with V<sub>CC</sub>.

V<sub>EE</sub> can vary +0.25 V / -0.5 V for +25°C and +85°C. or V<sub>EE</sub> can vary +0.06 V / -0.5 V for -40°C.

2. Outputs are terminated through a 50 ohm resistor to V<sub>CC</sub>-2 volts.

## 10EL SERIES NECL DC CHARACTERISTICS V<sub>CC</sub>= 0.0 V; V<sub>EE</sub>= -5.0 V (Note 1.)

Symbol	Characteristic	-40°C			25°C			85°C			Unit
		Min	Typ	Max	Min	Typ	Max	Min	Typ	Max	
I <sub>EE</sub>	Power Supply Current		14	17		14	17		14	17	mA
V <sub>OH</sub>	Output HIGH Voltage (Note 2.)	-1080	-990	-890	-980	-895	-810	-910	-815	-720	mV
V <sub>OL</sub>	Output LOW Voltage (Note 2.)	-1950	-1800	-1650	-1950	-1790	-1630	-1950	-1773	-1595	mV
V <sub>IH</sub>	Input HIGH Voltage	-1230		-890	-1130		-810	-1060		-720	mV
V <sub>IL</sub>	Input LOW Voltage	-1950		-1500	-1950		-1480	-1950		-1445	mV
I <sub>IH</sub>	Input HIGH Current			250 150			250 150			250 150	μA
I <sub>IL</sub>	Input LOW Current	0.5			0.5			0.3			μA

NOTE: Devices are designed to meet the DC specifications shown in the above table, after thermal equilibrium has been established. The circuit is in a test socket or mounted on a printed circuit board and transverse air flow greater than 500 lfm is maintained.

1. Input and output parameters vary 1:1 with V<sub>CC</sub>.

V<sub>EE</sub> can vary +0.25 V / -0.5 V for +25°C and +85°C. or V<sub>EE</sub> can vary +0.06 V / -0.5 V for -40°C.

2. Outputs are terminated through a 50 ohm resistor to V<sub>CC</sub>-2 volts.

# MC10EL07, MC100EL07

## 100EL SERIES PECL DC CHARACTERISTICS $V_{CC}=5.0\text{ V}; V_{EE}=0.0\text{ V}$ (Note 1.)

Symbol	Characteristic	-40°C			25°C			85°C			Unit
		Min	Typ	Max	Min	Typ	Max	Min	Typ	Max	
$I_{EE}$	Power Supply Current		14	17		14	17		16	20	mA
$V_{OH}$	Output HIGH Voltage (Note 2.)	3915	3995	4120	3975	4045	4120	3975	4050	4120	mV
$V_{OL}$	Output LOW Voltage (Note 2.)	3170	3305	3445	3190	3295	3380	3190	3295	3380	mV
$V_{IH}$	Input HIGH Voltage	3835		4120	3835		4120	3835		4120	mV
$V_{IL}$	Input LOW Voltage	3190		3525	3190		3525	3190		3525	mV
$I_{IH}$	Input HIGH Current D0 D1			250 150			250 150			250 150	$\mu\text{A}$
$I_{IL}$	Input LOW Current	0.5			0.5			0.5			$\mu\text{A}$

NOTE: Devices are designed to meet the DC specifications shown in the above table, after thermal equilibrium has been established. The circuit is in a test socket or mounted on a printed circuit board and transverse air flow greater than 500 lfm is maintained.

1. Input and output parameters vary 1:1 with  $V_{CC}$ .  $V_{EE}$  can vary +0.8 V / -0.5 V.
2. Outputs are terminated through a 50 ohm resistor to  $V_{CC}$ -2 volts.

## 100EL SERIES NECL DC CHARACTERISTICS $V_{CC}=0.0\text{ V}; V_{EE}=-5.0\text{ V}$ (Note 1.)

Symbol	Characteristic	-40°C			25°C			85°C			Unit
		Min	Typ	Max	Min	Typ	Max	Min	Typ	Max	
$I_{EE}$	Power Supply Current		14	17		14	17		16	20	mA
$V_{OH}$	Output HIGH Voltage (Note 2.)	-1085	-1005	-880	-1025	-955	-880	-1025	-955	-880	mV
$V_{OL}$	Output LOW Voltage (Note 2.)	-1830	-1695	-1555	-1810	-1705	-1620	-1810	-1705	-1620	mV
$V_{IH}$	Input HIGH Voltage	-1165		-880	-1165		-880	-1165		-880	mV
$V_{IL}$	Input LOW Voltage	-1810		-1475	-1810		-1475	-1810		-1475	mV
$I_{IH}$	Input HIGH Current D0 D1			250 150			250 150			250 150	$\mu\text{A}$
$I_{IL}$	Input LOW Current	0.5			0.5			0.5			$\mu\text{A}$

NOTE: Devices are designed to meet the DC specifications shown in the above table, after thermal equilibrium has been established. The circuit is in a test socket or mounted on a printed circuit board and transverse air flow greater than 500 lfm is maintained.

1. Input and output parameters vary 1:1 with  $V_{CC}$ .  $V_{EE}$  can vary +0.8 V / -0.5 V.
2. Outputs are terminated through a 50 ohm resistor to  $V_{CC}$ -2 volts.

## AC CHARACTERISTICS $V_{CC}=5.0\text{ V}; V_{EE}=0.0\text{ V}$ or $V_{CC}=0.0\text{ V}; V_{EE}=-5.0\text{ V}$ (Note 1.)

Symbol	Characteristic	-40°C			25°C			85°C			Unit
		Min	Typ	Max	Min	Typ	Max	Min	Typ	Max	
$f_{max}$	Maximum Toggle Frequency		TBD			TBD			TBD		GHz
$t_{PLH}$ $t_{PHL}$	Propagation Delay to Output	90	250	435	150	260	395	170	280	415	ps
$t_{JITTER}$	Cycle-to-Cycle Jitter		TBD			TBD			TBD		ps
$t_r$ $t_f$	Output Rise/Fall Times Q (20% - 80%)	100	225	350	100	225	350	100	225	350	ps

1. 10 Series:  $V_{EE}$  can vary +0.25 V / -0.5 V for +25°C and +85°C. or  $V_{EE}$  can vary +0.06 V / -0.5 V for -40°C.  
100 Series:  $V_{EE}$  can vary +0.8 V / -0.5 V.

## MC10EL07, MC100EL07

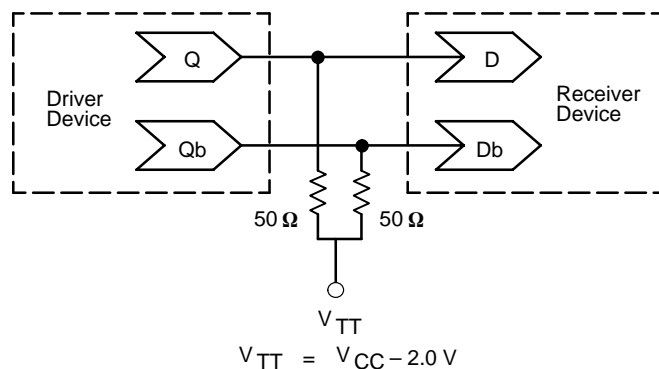

**Figure 1. Typical Termination for Output Driver and Device Evaluation  
(See Application Note AND8020 – Termination of ECL Logic Devices.)**

### Resource Reference of Application Notes

- AN1404** – ECLinPS Circuit Performance at Non-Standard  $V_{IH}$  Levels
- AN1405** – ECL Clock Distribution Techniques
- AN1406** – Designing with PECL (ECL at +5.0 V)
- AN1503** – ECLinPS I/O SPICE Modeling Kit
- AN1504** – Metastability and the ECLinPS Family
- AN1560** – Low Voltage ECLinPS SPICE Modeling Kit
- AN1568** – Interfacing Between LVDS and ECL
- AN1596** – ECLinPS Lite Translator ELT Family SPICE I/O Model Kit
- AN1650** – Using Wire-OR Ties in ECLinPS Designs
- AN1672** – The ECL Translator Guide
- AND8001** – Odd Number Counters Design
- AND8002** – Marking and Date Codes
- AND8020** – Termination of ECL Logic Devices

# MC10EL07, MC100EL07

## PACKAGE DIMENSIONS

SO-8  
D SUFFIX  
PLASTIC SOIC PACKAGE  
CASE 751-07  
ISSUE V

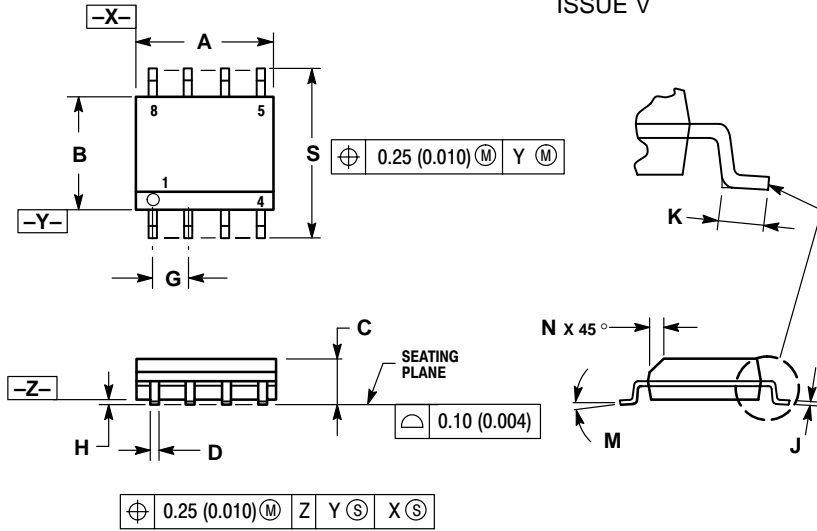

- NOTES:
1. DIMENSIONING AND TOLERANCING PER ANSI Y14.5M, 1982.
  2. CONTROLLING DIMENSION: MILLIMETER.
  3. DIMENSION A AND B DO NOT INCLUDE MOLD PROTRUSION.
  4. MAXIMUM MOLD PROTRUSION 0.15 (0.006) PER SIDE.
  5. DIMENSION D DOES NOT INCLUDE DAMBAR PROTRUSION. ALLOWABLE DAMBAR PROTRUSION SHALL BE 0.127 (0.005) TOTAL IN EXCESS OF THE D DIMENSION AT MAXIMUM MATERIAL CONDITION.

DIM	MILLIMETERS		INCHES	
	MIN	MAX	MIN	MAX
A	4.80	5.00	0.189	0.197
B	3.80	4.00	0.150	0.157
C	1.35	1.75	0.053	0.069
D	0.33	0.51	0.013	0.020
G	1.27 BSC		0.050 BSC	
H	0.10	0.25	0.004	0.010
J	0.19	0.25	0.007	0.010
K	0.40	1.27	0.016	0.050
M	0°	8°	0°	8°
N	0.25	0.50	0.010	0.020
S	5.80	6.20	0.228	0.244

# MC10EL07, MC100EL07

## PACKAGE DIMENSIONS

TSSOP-8  
DT SUFFIX  
PLASTIC TSSOP PACKAGE  
CASE 948R-02  
ISSUE A

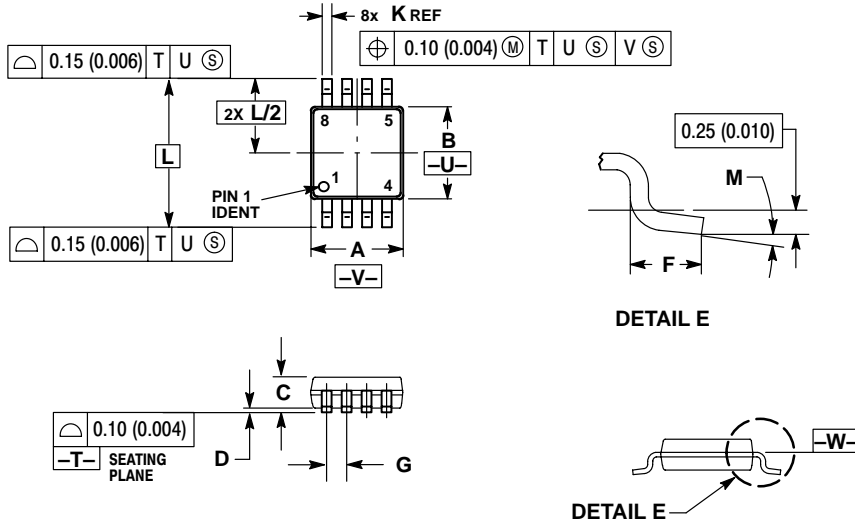

### NOTES:

1. DIMENSIONING AND TOLERANCING PER ANSI Y14.5M, 1982.
2. CONTROLLING DIMENSION: MILLIMETER.
3. DIMENSION A DOES NOT INCLUDE MOLD FLASH. PROTRUSIONS OR GATE BURRS. MOLD FLASH OR GATE BURRS SHALL NOT EXCEED 0.15 (0.006) PER SIDE.
4. DIMENSION B DOES NOT INCLUDE INTERLEAD FLASH OR PROTRUSION. INTERLEAD FLASH OR PROTRUSION SHALL NOT EXCEED 0.25 (0.010) PER SIDE.
5. TERMINAL NUMBERS ARE SHOWN FOR REFERENCE ONLY.
6. DIMENSION A AND B ARE TO BE DETERMINED AT DATUM PLANE -W-.

DIM	MILLIMETERS		INCHES	
	MIN	MAX	MIN	MAX
A	2.90	3.10	0.114	0.122
B	2.90	3.10	0.114	0.122
C	0.80	1.10	0.031	0.043
D	0.05	0.15	0.002	0.006
F	0.40	0.70	0.016	0.028
G	0.65 BSC		0.026 BSC	
K	0.25	0.40	0.010	0.016
L	4.90 BSC		0.193 BSC	
M	0°	6°	0°	6°

## Notes

**ON Semiconductor** and  are trademarks of Semiconductor Components Industries, LLC (SCILLC). SCILLC reserves the right to make changes without further notice to any products herein. SCILLC makes no warranty, representation or guarantee regarding the suitability of its products for any particular purpose, nor does SCILLC assume any liability arising out of the application or use of any product or circuit, and specifically disclaims any and all liability, including without limitation special, consequential or incidental damages. "Typical" parameters which may be provided in SCILLC data sheets and/or specifications can and do vary in different applications and actual performance may vary over time. All operating parameters, including "Typicals" must be validated for each customer application by customer's technical experts. SCILLC does not convey any license under its patent rights nor the rights of others. SCILLC products are not designed, intended, or authorized for use as components in systems intended for surgical implant into the body, or other applications intended to support or sustain life, or for any other application in which the failure of the SCILLC product could create a situation where personal injury or death may occur. Should Buyer purchase or use SCILLC products for any such unintended or unauthorized application, Buyer shall indemnify and hold SCILLC and its officers, employees, subsidiaries, affiliates, and distributors harmless against all claims, costs, damages, and expenses, and reasonable attorney fees arising out of, directly or indirectly, any claim of personal injury or death associated with such unintended or unauthorized use, even if such claim alleges that SCILLC was negligent regarding the design or manufacture of the part. SCILLC is an Equal Opportunity/Affirmative Action Employer.

## PUBLICATION ORDERING INFORMATION

### **NORTH AMERICA Literature Fulfillment:**

Literature Distribution Center for ON Semiconductor  
P.O. Box 5163, Denver, Colorado 80217 USA  
**Phone:** 303-675-2175 or 800-344-3860 Toll Free USA/Canada  
**Fax:** 303-675-2176 or 800-344-3867 Toll Free USA/Canada  
**Email:** ONlit@hibbertco.com  
Fax Response Line: 303-675-2167 or 800-344-3810 Toll Free USA/Canada

**N. American Technical Support:** 800-282-9855 Toll Free USA/Canada

**EUROPE:** LDC for ON Semiconductor – European Support

**German Phone:** (+1) 303-308-7140 (Mon-Fri 2:30pm to 7:00pm CET)  
**Email:** ONlit-german@hibbertco.com  
**French Phone:** (+1) 303-308-7141 (Mon-Fri 2:00pm to 7:00pm CET)  
**Email:** ONlit-french@hibbertco.com  
**English Phone:** (+1) 303-308-7142 (Mon-Fri 12:00pm to 5:00pm GMT)  
**Email:** ONlit@hibbertco.com

**EUROPEAN TOLL-FREE ACCESS\*: 00-800-4422-3781**

\*Available from Germany, France, Italy, UK, Ireland

### **CENTRAL/SOUTH AMERICA:**

**Spanish Phone:** 303-308-7143 (Mon-Fri 8:00am to 5:00pm MST)  
**Email:** ONlit-spanish@hibbertco.com  
**Toll-Free from Mexico:** Dial 01-800-288-2872 for Access –  
then Dial 866-297-9322

**ASIA/PACIFIC:** LDC for ON Semiconductor – Asia Support

**Phone:** 303-675-2121 (Tue-Fri 9:00am to 1:00pm, Hong Kong Time)  
**Toll Free from Hong Kong & Singapore:**  
**001-800-4422-3781**  
**Email:** ONlit-asia@hibbertco.com

**JAPAN:** ON Semiconductor, Japan Customer Focus Center

4-32-1 Nishi-Gotanda, Shinagawa-ku, Tokyo, Japan 141-0031  
**Phone:** 81-3-5740-2700  
**Email:** r14525@onsemi.com

**ON Semiconductor Website:** <http://onsemi.com>

For additional information, please contact your local Sales Representative.