

256K x 8 HIGH-SPEED CMOS STATIC RAM

APRIL 2003

FEATURES

- High-speed access time:
 - IS61LV2568L: 8, 10 ns
 - IS61LV2568LL: 12 ns
- Operating Current:
 - IS61LV2568L: 50mA (typ.)
 - IS61LV2568LL: 30mA (typ.)
- Standby Current:
 - IS61LV2568L: 700 μ A (typ.)
 - IS61LV2568LL: 400 μ A (typ.)
- Multiple center power and ground pins for greater noise immunity
- Easy memory expansion with \overline{CE} and \overline{OE} options
- \overline{CE} power-down
- TTL compatible inputs and outputs
- Single 3.3V power supply
- Packages available:
 - 36-pin 400-mil SOJ
 - 44-pin TSOP (Type II)
 - 36-ball mini BGA (6mm x 8mm)

DESCRIPTION

The *ISSI* IS61LV2568L/IS61LV2568LL is a very high-speed, low power, 262,144-word by 8-bit CMOS static RAM. The IS61LV2568L/IS61LV2568LL is fabricated using *ISSI*'s high-performance CMOS technology. This highly reliable process coupled with innovative circuit design techniques, yields higher performance and low power consumption devices.

When \overline{CE} is HIGH (deselected), the device assumes a standby mode at which the power dissipation can be reduced down to 36mW (max.) with CMOS input levels.

The S61LV2568L/IS61LV2568LL operates from a single 3.3V power supply and all inputs are TTL-compatible.

The S61LV2568L/IS61LV2568LL is available in 36-pin 400-mil SOJ, 44-pin TSOP (Type II), and 36-ball mini BGA (6mm x 8mm) packages.

FUNCTIONAL BLOCK DIAGRAM

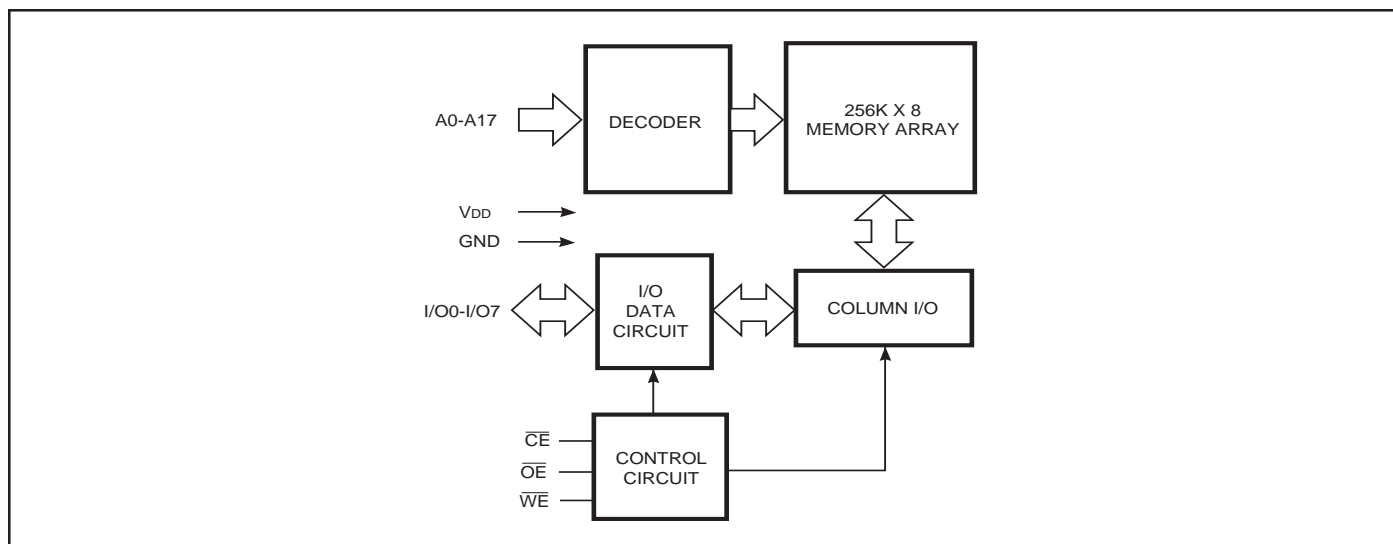

Copyright © 2003 Integrated Silicon Solution, Inc. All rights reserved. ISSI reserves the right to make changes to this specification and its products at any time without notice. ISSI assumes no liability arising out of the application or use of any information, products or services described herein. Customers are advised to obtain the latest version of this device specification before relying on any published information and before placing orders for products.

PIN CONFIGURATION

36-Pin SOJ

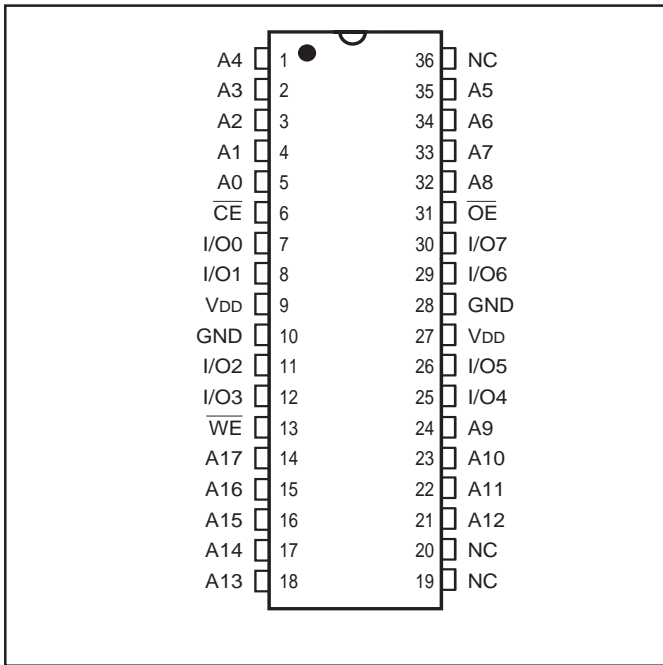

44-Pin TSOP (Type II)

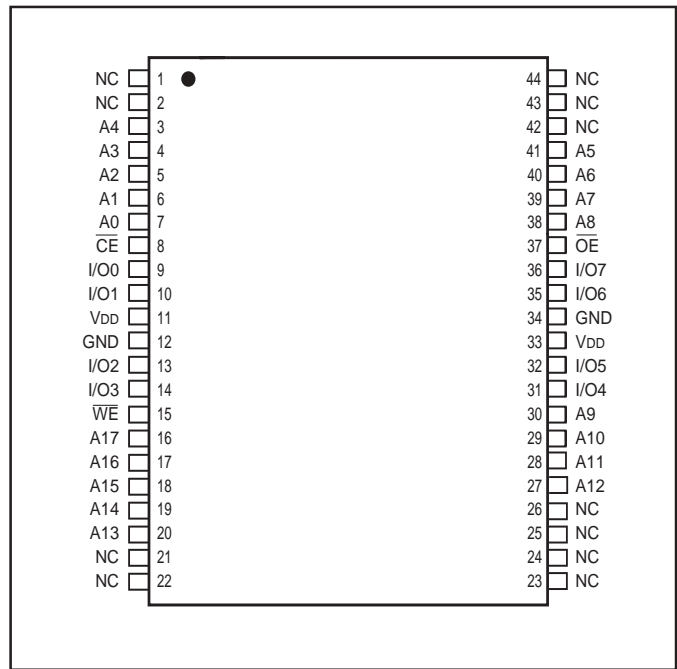

36 Ball mini BGA (6mm x 8mm)

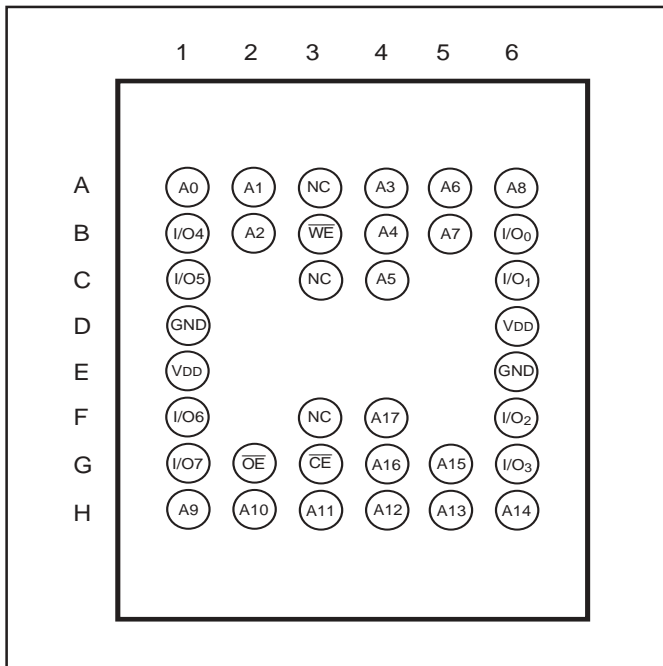

PIN DESCRIPTIONS

A0-A17	Address Inputs
\overline{CE}	Chip Enable Input
\overline{OE}	Output Enable Input
\overline{WE}	Write Enable Input
I/O0-I/O7	Bidirectional Ports
VDD	Power
GND	Ground
NC	No Connection

TRUTH TABLE

Mode	\overline{WE}	\overline{CE}	\overline{OE}	I/O Operation	V _{DD} Current
Not Selected (Power-down)	X	H	X	High-Z	I _{SB1} , I _{SB2}
Output Disabled	H	L	H	High-Z	I _{CC}
Read	H	L	L	D _{OUT}	I _{CC}
Write	L	L	X	D _{IN}	I _{CC}

ABSOLUTE MAXIMUM RATINGS⁽¹⁾

Symbol	Parameter	Value	Unit
V _{DD}	Supply voltage with Respect to GND	-0.5 to +4.0	V
V _{TERM}	Terminal Voltage with Respect to GND	-0.5 to V _{DD} + 0.5	V
T _{STG}	Storage Temperature	-65 to +150	°C
P _D	Power Dissipation	1.0	W

Notes:

1. Stress greater than those listed under ABSOLUTE MAXIMUM RATINGS may cause permanent damage to the device. This is a stress rating only and functional operation of the device at these or any other conditions above those indicated in the operational sections of this specification is not implied. Exposure to absolute maximum rating conditions for extended periods may affect reliability.

OPERATING RANGE

Range	Ambient Temperature	V _{DD} (8ns)	V _{DD} (10 ns, 12 ns)
Commercial	0°C to +70°C	3.3V +10%,-5%	3.3V ± 10%
Industrial	-40°C to +85°C	3.3V +10%,-5%	3.3V ± 10%

DC ELECTRICAL CHARACTERISTICS (Over Operating Range)

Symbol	Parameter	Test Conditions	Min.	Max.	Unit
V _{OH}	Output HIGH Voltage	V _{DD} = Min., I _{OH} = -4.0 mA	2.4	—	V
V _{OL}	Output LOW Voltage	V _{DD} = Min., I _{OL} = 8.0 mA	—	0.4	V
V _{IH}	Input HIGH Voltage ⁽¹⁾		2.0	V _{DD} + 0.3	V
V _{IL}	Input LOW Voltage ⁽¹⁾		-0.3	0.8	V
I _{LI}	Input Leakage	GND ≤ V _{IN} ≤ V _{DD}	-1	1	μA
I _{LO}	Output Leakage	GND ≤ V _{OUT} ≤ V _{DD} , Outputs Disabled	-1	1	μA

Note:

1. V_{IL}(min) = -0.3V (DC); V_{IL}(min) = -2.0V (pulse width - 2.0 ns).
V_{IH}(max) = V_{DD} + 0.3V (DC); V_{IH}(max) = V_{DD} + 2.0V (pulse width - 2.0 ns).

POWER SUPPLY CHARACTERISTICS⁽¹⁾ (Over Operating Range)**IS61LV2568L**

Symbol	Parameter	Test Conditions		-8 ns		-10 ns		Unit
				Min.	Max.	Min.	Max.	
I _{CC}	V _{DD} Operating Supply Current	V _{DD} = Max., $\overline{CE} = V_{IL}$ I _{OUT} = 0 mA, f = Max.	Com.	—	65	—	60	mA
			Ind.	—	70	—	65	
			typ. ⁽²⁾	—	50	—	50	
I _{SB1}	TTL Standby Current (TTL Inputs)	V _{DD} = Max., V _{IN} = V _{IH} or V _{IL} $\overline{CE} \geq V_{IH}$, f = max	Com.	—	30	—	25	mA
			Ind.	—	35	—	30	
I _{SB2}	CMOS Standby Current (CMOS Inputs)	V _{DD} = Max., $\overline{CE} \geq V_{DD} - 0.2V$, V _{IN} $\geq V_{DD} - 0.2V$, or V _{IN} $\leq 0.2V$, f = 0	Com.	—	3	—	3	mA
			Ind.	—	4	—	4	
			typ. ⁽²⁾	—	700	—	700	

Note:

- At f = f_{MAX}, address and data inputs are cycling at the maximum frequency, f = 0 means no input lines change.
- Typical values are measured at V_{DD}=3.3V, T_A=25°C. Not 100% tested.

POWER SUPPLY CHARACTERISTICS⁽¹⁾ (Over Operating Range)**IS61LV2568LL**

Symbol	Parameter	Test Conditions		-12 ns		Unit
				Min.	Max.	
I _{CC}	V _{DD} Operating Supply Current	V _{DD} = Max., $\overline{CE} = V_{IL}$ I _{OUT} = 0 mA, f = Max.	Com.	—	40	mA
			Ind.	—	45	
			typ. ⁽²⁾	—	30	
			@ 15ns ⁽³⁾	—	25	
I _{SB1}	TTL Standby Current (TTL Inputs)	V _{DD} = Max., V _{IN} = V _{IH} or V _{IL} $\overline{CE} \geq V_{IH}$, f = max	Com.	—	20	mA
			Ind.	—	25	
I _{SB2}	CMOS Standby Current (CMOS Inputs)	V _{DD} = Max., $\overline{CE} \geq V_{DD} - 0.2V$, V _{IN} $\geq V_{DD} - 0.2V$, or V _{IN} $\leq 0.2V$, f = 0	Com.	—	750	μA
			Ind.	—	900	
			typ. ⁽²⁾	—	400	

Note:

- At f = f_{MAX}, address and data inputs are cycling at the maximum frequency, f = 0 means no input lines change.
- Typical values are measured at V_{DD}=3.3V, T_A=25°C. Not 100% tested.
- For 15ns speed (t_{AA}), I_{CC} is measured at V_{DD}=3.3V, T_A=25°C. Not 100% tested.

CAPACITANCE^(1,2)

Symbol	Parameter	Conditions	Max.	Unit
C _{IN}	Input Capacitance	V _{IN} = 0V	6	pF
C _{I/O}	Input/Output Capacitance	V _{OUT} = 0V	8	pF

Notes:

- Tested initially and after any design or process changes that may affect these parameters.
- Test conditions: T_A = 25°C, f = 1 MHz, V_{DD} = 3.3V.

AC TEST CONDITIONS

Parameter	Unit
Input Pulse Level	0V to 3.0V
Input Rise and Fall Times	3 ns
Input and Output Timing and Reference Levels	1.5V
Output Load	See Figures 1 and 2

AC TEST LOADS

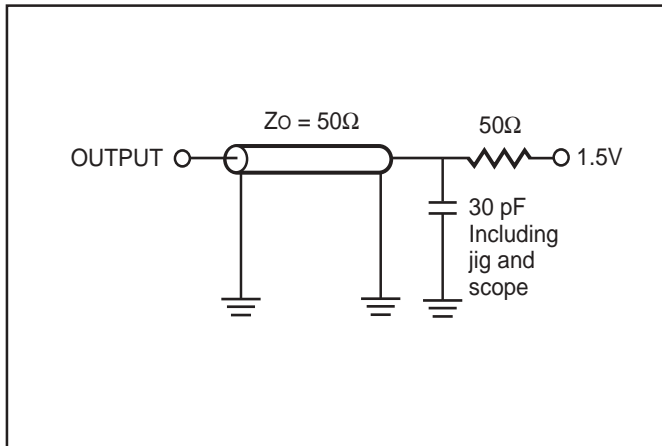

Figure 1

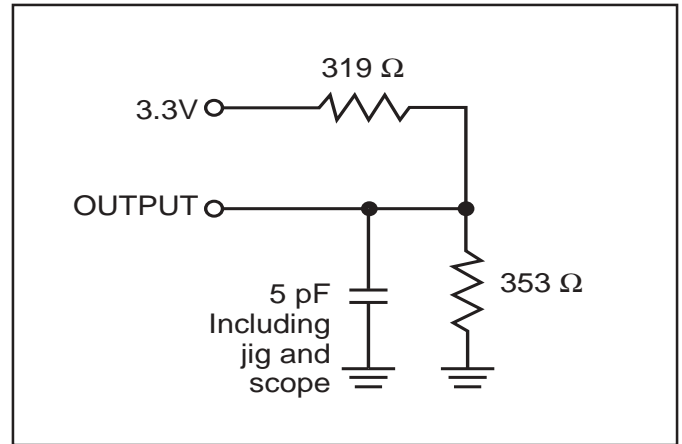

Figure 2

READ CYCLE SWITCHING CHARACTERISTICS⁽¹⁾ (Over Operating Range)

IS61LV2568L

Symbol	Parameter	- 8 ns		-10 ns		Unit
		Min.	Max	Min.	Max.	
t _{RC}	Read Cycle Time	8	—	10	—	ns
t _{AA}	Address Access Time	—	8	—	10	ns
t _{OHA}	Output Hold Time	2.5	—	2.5	—	ns
t _{ACE}	$\overline{\text{CE}}$ Access Time	—	8	—	10	ns
t _{DOE}	$\overline{\text{OE}}$ Access Time	—	3.5	—	4	ns
t _{LZOE} ⁽²⁾	$\overline{\text{OE}}$ to Low-Z Output	0	—	0	—	ns
t _{HZOE} ⁽²⁾	$\overline{\text{OE}}$ to High-Z Output	0	3.5	0	4	ns
t _{LZCE} ⁽²⁾	$\overline{\text{CE}}$ to Low-Z Output	3.5	—	3	—	ns
t _{HZCE} ⁽²⁾	$\overline{\text{CE}}$ to High-Z Output	0	3.5	0	4	ns

Notes:

1. Test conditions assume signal transition times of 3 ns or less, timing reference levels of 1.5V, input pulse levels of 0 to 3.0V and output loading specified in Figure 1.
2. Tested with the load in Figure 2. Transition is measured ± 200 mV from steady-state voltage. Not 100% tested.

READ CYCLE SWITCHING CHARACTERISTICS⁽¹⁾ (Over Operating Range)

IS61LV2568LL

Symbol	Parameter	- 12 ns		Unit
		Min.	Max	
t _{RC}	Read Cycle Time	12	—	ns
t _{AA}	Address Access Time	—	12	ns
t _{OHA}	Output Hold Time	3	—	ns
t _{ACE}	$\overline{\text{CE}}$ Access Time	—	12	ns
t _{DOE}	$\overline{\text{OE}}$ Access Time	—	5	ns
t _{LZOE} ⁽²⁾	$\overline{\text{OE}}$ to Low-Z Output	0	—	ns
t _{HZOE} ⁽²⁾	$\overline{\text{OE}}$ to High-Z Output	0	5	ns
t _{LZCE} ⁽²⁾	$\overline{\text{CE}}$ to Low-Z Output	3	—	ns
t _{HZCE} ⁽²⁾	$\overline{\text{CE}}$ to High-Z Output	0	5	ns

Notes:

1. Test conditions assume signal transition times of 3 ns or less, timing reference levels of 1.5V, input pulse levels of 0 to 3.0V and output loading specified in Figure 1.
2. Tested with the load in Figure 2. Transition is measured ± 200 mV from steady-state voltage. Not 100% tested.

AC WAVEFORMS

READ CYCLE NO. 1^(1,2) (Address Controlled) ($\overline{CE} = \overline{OE} = V_{IL}$)

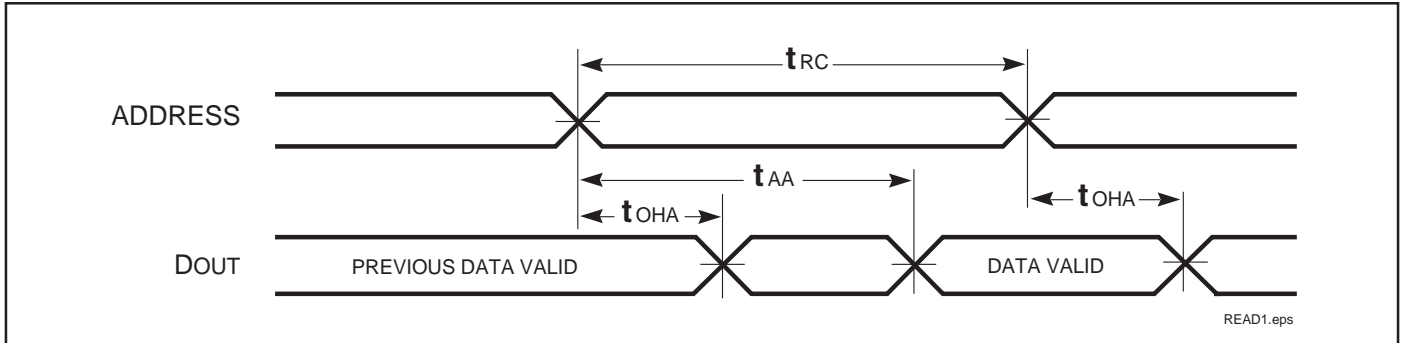

READ CYCLE NO. 2^(1,3) (\overline{CE} and \overline{OE} Controlled)

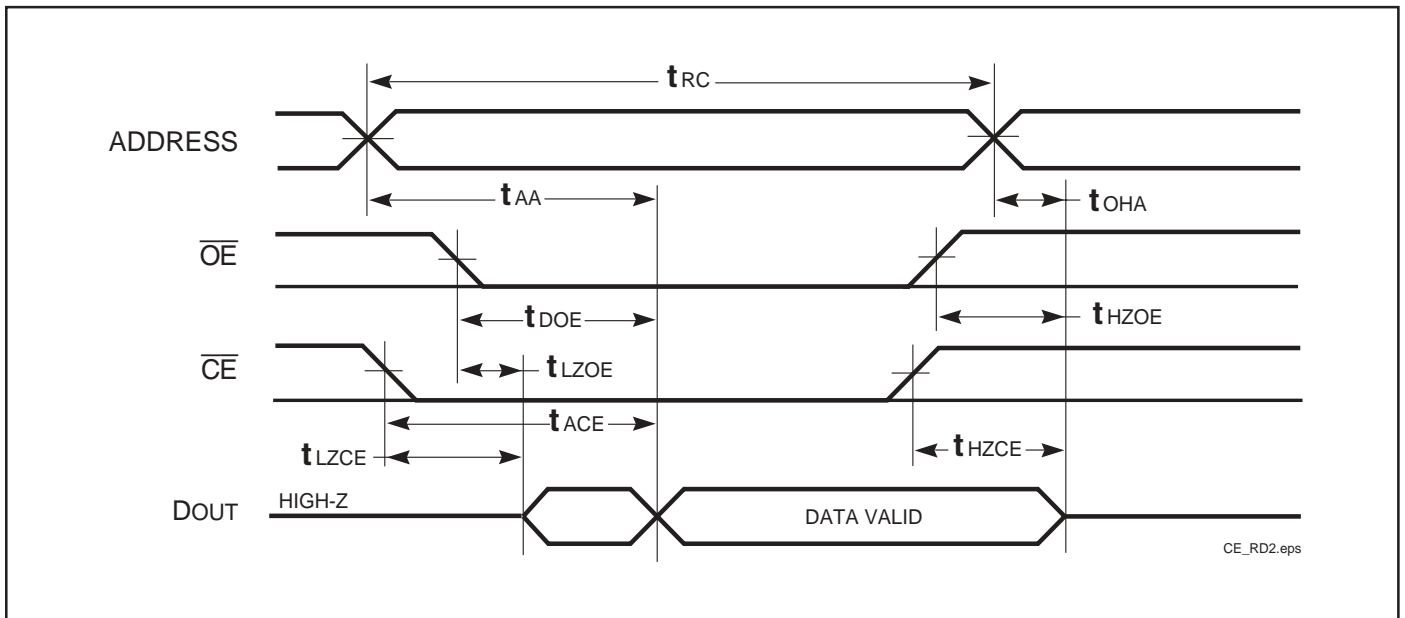

Notes:

1. \overline{WE} is HIGH for a Read Cycle.
2. The device is continuously selected. $\overline{OE}, \overline{CE} = V_{IL}$.
3. Address is valid prior to or coincident with \overline{CE} LOW transitions.

WRITE CYCLE SWITCHING CHARACTERISTICS^(1,2) (Over Operating Range)

IS61LV2568L

Symbol	Parameter	- 8 ns		-10 ns		Unit
		Min.	Max	Min.	Max.	
t _{WC}	Write Cycle Time	8	—	10	—	ns
t _{SCE}	\overline{CE} to Write End	7	—	8	—	ns
t _{AW}	Address Setup Time to Write End	7	—	8	—	ns
t _{HA}	Address Hold from Write End	0	—	0	—	ns
t _{SA}	Address Setup Time	0	—	0	—	ns
t _{PWE1}	\overline{WE} Pulse Width (\overline{OE} = HIGH)	6	—	7	—	ns
t _{PWE2}	\overline{WE} Pulse Width (\overline{OE} = LOW)	6.5	—	8	—	ns
t _{SD}	Data Setup to Write End	4	—	5	—	ns
t _{HD}	Data Hold from Write End	0	—	0	—	ns
t _{HZWE} ⁽³⁾	\overline{WE} LOW to High-Z Output	—	3	—	4	ns
t _{LZWE} ⁽³⁾	\overline{WE} HIGH to Low-Z Output	0	—	0	—	ns

Notes:

1. Test conditions assume signal transition times of 3 ns or less, timing reference levels of 1.5V, input pulse levels of 0 to 3.0V and output loading specified in Figure 1.
2. The internal write time is defined by the overlap of \overline{CE} LOW and \overline{WE} LOW. All signals must be in valid states to initiate a Write, but any one can go inactive to terminate the Write. The Data Input Setup and Hold timing are referenced to the rising or falling edge of the signal that terminates the Write.
3. Tested with the load in Figure 2. Transition is measured ± 500 mV from steady-state voltage. Not 100% tested.

WRITE CYCLE SWITCHING CHARACTERISTICS^(1,2) (Over Operating Range)

IS61LV2568LL

Symbol	Parameter	- 12ns		Unit
		Min.	Max	
t _{WC}	Write Cycle Time	12	—	ns
t _{SCE}	\overline{CE} to Write End	8	—	ns
t _{AW}	Address Setup Time to Write End	8	—	ns
t _{HA}	Address Hold from Write End	0	—	ns
t _{SA}	Address Setup Time	0	—	ns
t _{PWE1}	\overline{WE} Pulse Width ($\overline{OE} = \text{HIGH}$)	8	—	ns
t _{PWE2}	\overline{WE} Pulse Width ($\overline{OE} = \text{LOW}$)	10	—	ns
t _{SD}	Data Setup to Write End	6	—	ns
t _{HD}	Data Hold from Write End	0	—	ns
t _{HZWE⁽³⁾}	\overline{WE} LOW to High-Z Output	—	5	ns
t _{LZWE⁽³⁾}	\overline{WE} HIGH to Low-Z Output	0	—	ns

Notes:

1. Test conditions assume signal transition times of 3 ns or less, timing reference levels of 1.5V, input pulse levels of 0 to 3.0V and output loading specified in Figure 1.
2. The internal write time is defined by the overlap of \overline{CE} LOW and \overline{WE} LOW. All signals must be in valid states to initiate a Write, but any one can go inactive to terminate the Write. The Data Input Setup and Hold timing are referenced to the rising or falling edge of the signal that terminates the Write.
3. Tested with the load in Figure 2. Transition is measured ± 500 mV from steady-state voltage. Not 100% tested.

AC WAVEFORMS

WRITE CYCLE NO. 1^(1,2) (\overline{CE} Controlled, $\overline{OE} = \text{HIGH or LOW}$)

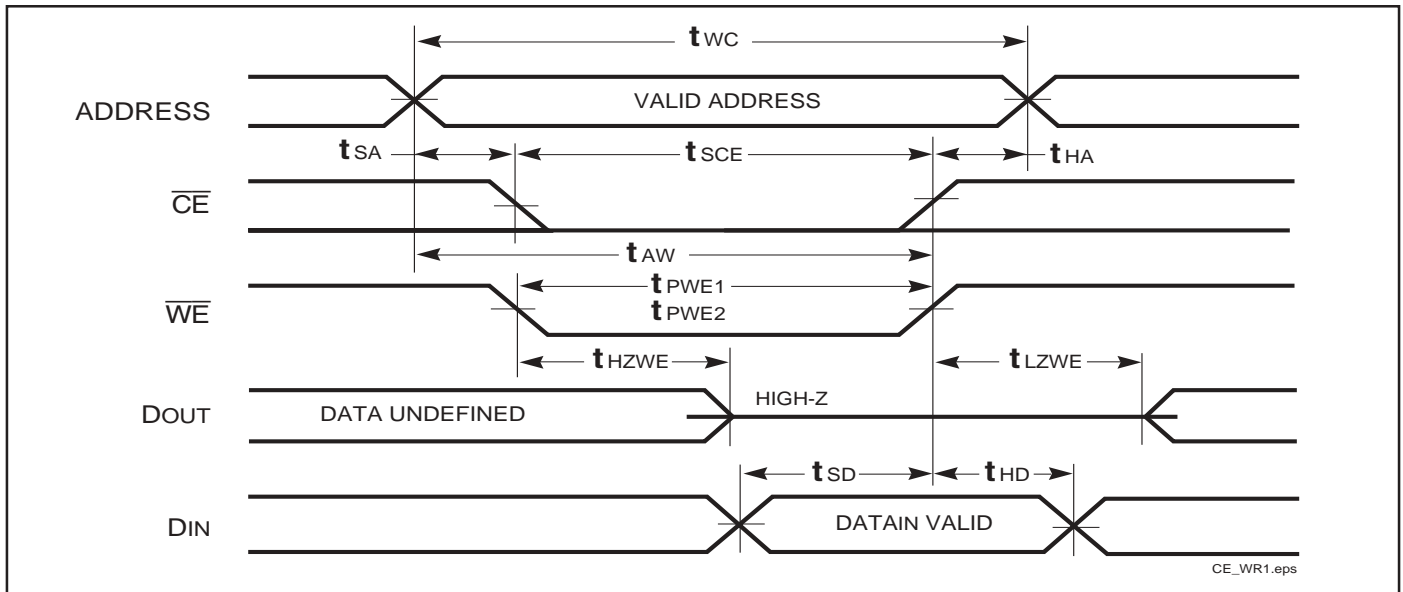

Note:

1. The internal Write time is defined by the overlap of $\overline{CE} = \text{LOW}$ and $\overline{WE} = \text{LOW}$. All signals must be in valid states to initiate a Write, but any one can be deasserted to terminate the Write. The Data Input Setup and Hold timing is referenced to the rising or falling edge of the signal that terminates the Write.

AC WAVEFORMS

WRITE CYCLE NO. 2⁽¹⁾ (\overline{WE} Controlled, \overline{OE} = HIGH during Write Cycle)

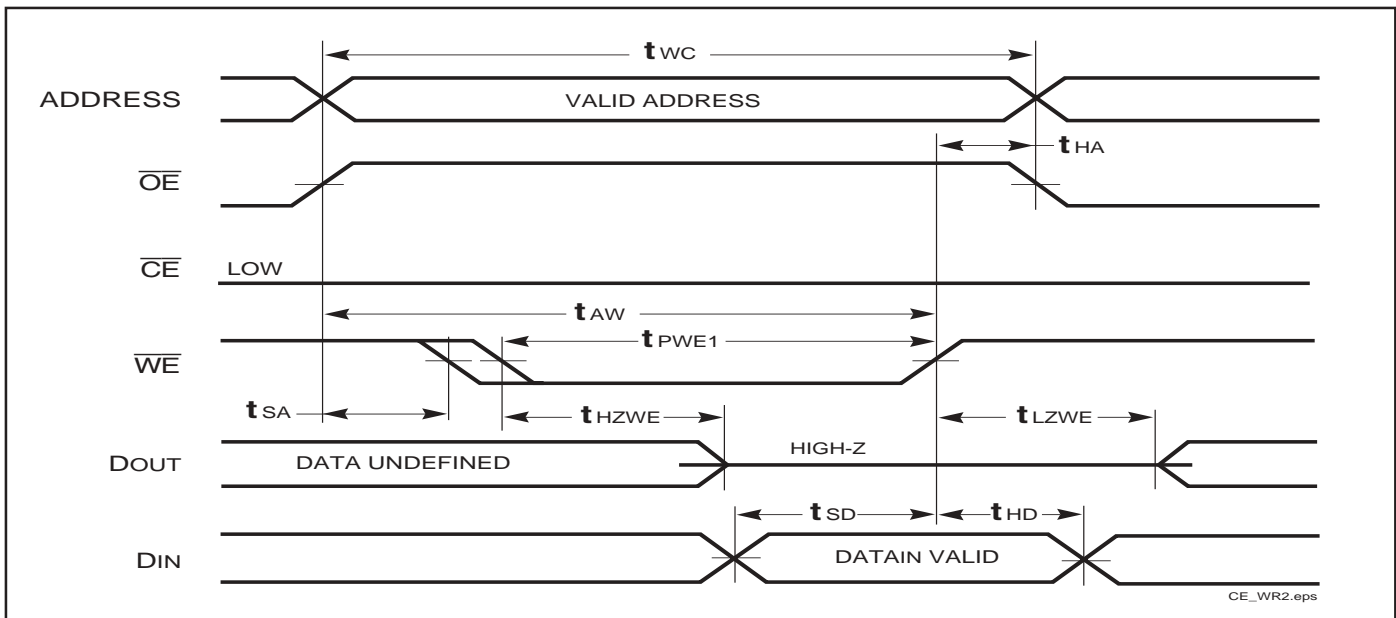

Note:

1. The internal Write time is defined by the overlap of \overline{CE} = LOW and \overline{WE} = LOW. All signals must be in valid states to initiate a Write, but any can be deasserted to terminate the Write. The Data Input Setup and Hold timing is referenced to the rising or falling edge of the signal that terminates the Write.

WRITE CYCLE NO. 3 (\overline{WE} Controlled: \overline{OE} is LOW During Write Cycle)

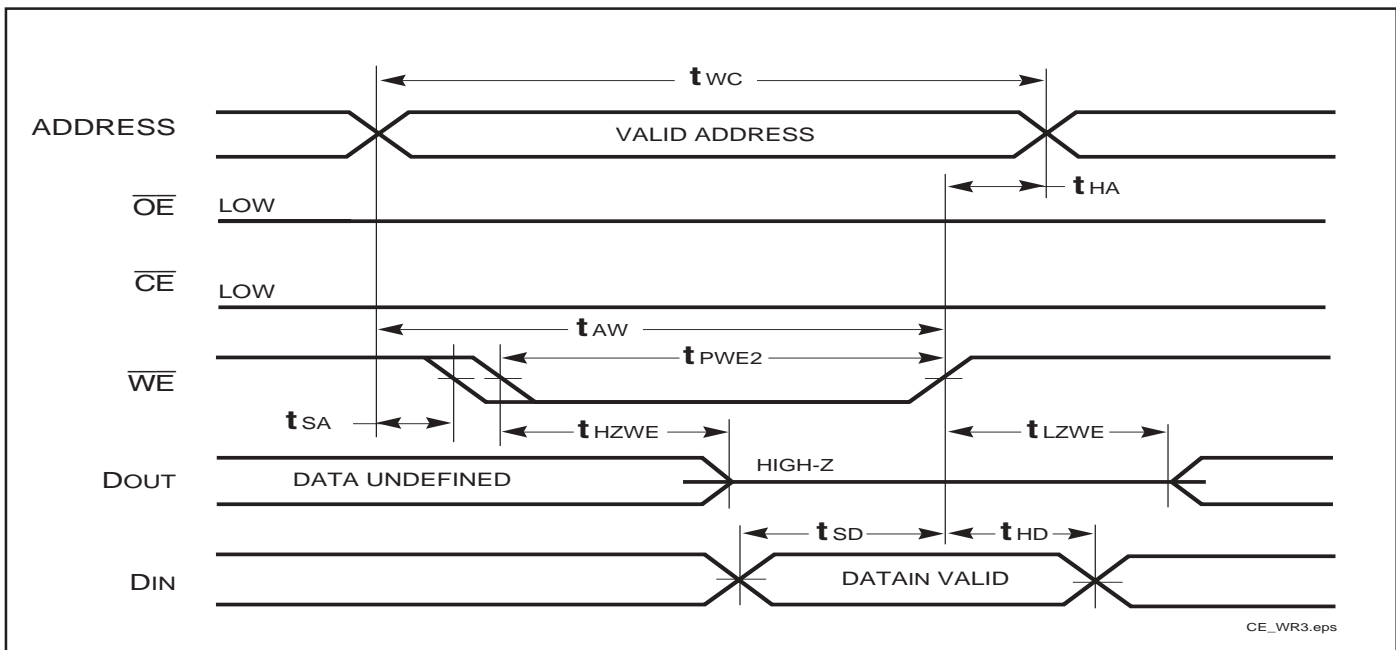

Note:

1. The internal Write time is defined by the overlap of \overline{CE} = LOW and \overline{WE} = LOW. All signals must be in valid states to initiate a Write, but any can be deasserted to terminate the Write. The Data Input Setup and Hold timing is referenced to the rising or falling edge of the signal that terminates the Write.

IS61LV2568L, IS61LV2568LL**ORDERING INFORMATION****IS61LV2568L****Commercial Range: 0°C to +70°C**

Speed (ns)	Order Part No.	Package
8	IS61LV2568L-8B	mini BGA (6mm x 8mm)
	IS61LV2568L-8K	400-mil SOJ
	IS61LV2568L-8T	TSOP (Type II)
10	IS61LV2568L-10T	TSOP (Type II)

IS61LV2568L**Industrial Range: -40°C to +85°C**

Speed (ns)	Order Part No.	Package
8	IS61LV2568L-8BI	mini BGA (6mm x 8mm)
	IS61LV2568L-8KI	400-mil SOJ
	IS61LV2568L-8TI	TSOP (Type II)
10	IS61LV2568L-10BI	mini BGA (6mm x 8mm)
	IS61LV2568L-10KI	400-mil SOJ
	IS61LV2568L-10TI	TSOP (Type II)

IS61LV2568LL**Commercial Range: 0°C to +70°C**

Speed (ns)	Order Part No.	Package
12	IS61LV2568LL-12T	TSOP (Type II)

IS61LV2568LL**Industrial Range: -40°C to +85°C**

Speed (ns)	Order Part No.	Package
12	IS61LV2568LL-12BI	mini BGA (6mm x 8mm)
	IS61LV2568LL-12KI	400-mil SOJ
	IS61LV2568LL-12TI	TSOP (Type II)