

DATA SHEET

KM110BH/2430; KM110BH/2470 30° and 70° angle sensor hybrids

Preliminary specification
Supersedes data of November 1994
File under Discrete Semiconductors, SC17

1996 Nov 08

30° and 70° angle sensor hybrids

KM110BH/2430; KM110BH/2470

FEATURES

- Angle measuring range 30° or 70°
- Contactless, therefore wear-free and no microlinearity problems
- Easy to mount, ready for use
- Analog voltage output signal
- Operating temperatures up to 125 °C
- Precision of ± 0.5° in the temperature range (-15° ≤ α ≤ +15°)
- EMC resistant
- Sample kit with magnet available.

DESCRIPTION

The KM110BH/2430 and the KM110BH/2470 are sensor modules for contactless measurement of angular displacements of strong magnetic fields. The modules are a ready-trimmed (sensitivity and zero point) combination of a magnetoresistive KMZ sensor and a signal conditioning circuit in hybrid technology.

The KM110BH/2430 delivers a voltage output signal which is a linear function of the direction of the magnetic field. The KM110BH/2470 delivers a sinusoidal voltage output signal. The modules can be used for contactless angle measurement.

PINNING

PIN	SYMBOL	DESCRIPTION
1	GND	ground
2	V _{CC}	DC supply voltage
3	V _O	output voltage

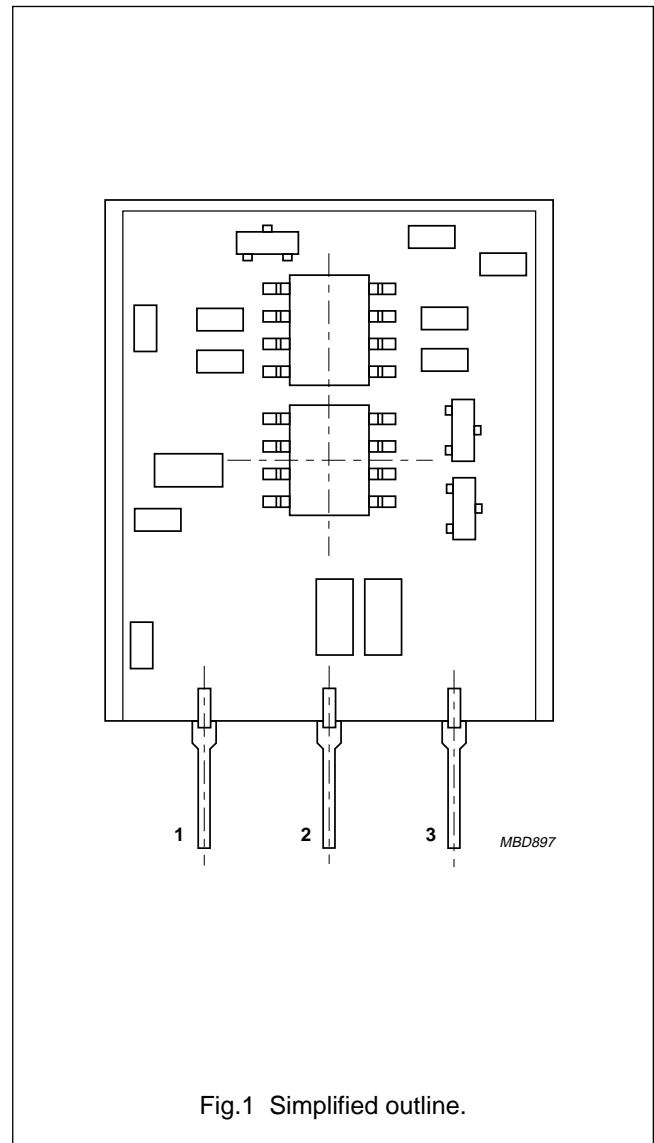

Fig.1 Simplified outline.

QUICK REFERENCE DATA

SYMBOL	PARAMETER	MIN.	TYP.	MAX.	UNIT
V _{CC}	DC supply voltage	4.5	5	16	V
T _{oper}	operating temperature	-40	-	+125	°C
α	angle range:				
	KM110BH/2430	-	-15 to +15	-	deg
	KM110BH/2470	-	-35 to +35	-	deg
V _O	output voltage range	-	0.5 to 4.5	-	V

30° and 70° angle sensor hybrids

KM110BH/2430;
KM110BH/2470

EMC RESISTIVITY

The EMC compatibility is dependent on the assembly of the sensors. The EMC resistivity has to be tested in the final application.

BLOCK DIAGRAM

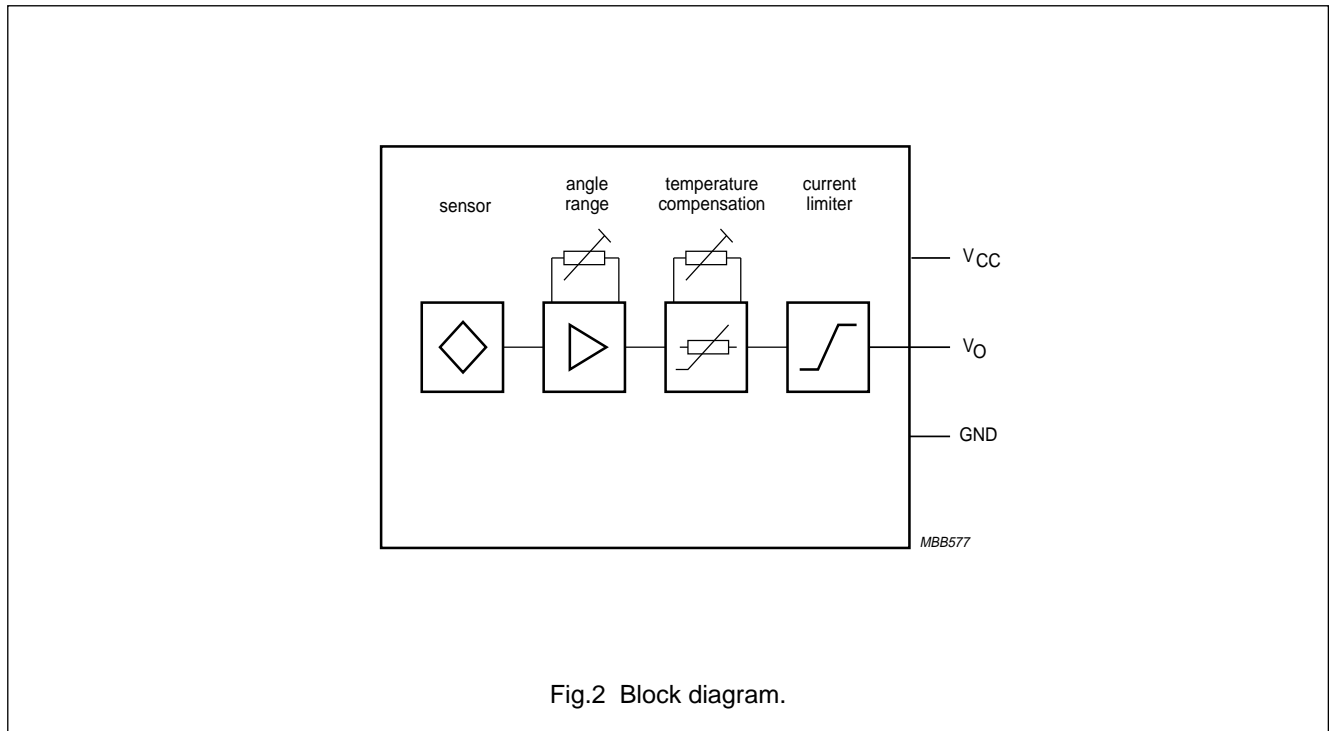

Fig.2 Block diagram.

LIMITING VALUES

In accordance with the Absolute Maximum Rating System (IEC 134).

SYMBOL	PARAMETER	MIN.	MAX.	UNIT
V _{CC}	DC supply voltage	4.5	16	V
I _{CC}	supply current	–	15	mA
T _{stg}	storage temperature	–40	+125	°C
T _{oper}	operating temperature; note 1	–40	+125	°C
	output short-circuit duration	permanent; see note 2		

Notes

1. For operations above T_{oper} = 100 °C, maximum V_{CC} derates linearly from 16 V to 5 V at T_{oper} = 125 °C.
2. If pin 3 is shorted to either pin 1 or pin 2, a current may flow permanently, without damaging the device.

30° and 70° angle sensor hybrids

KM110BH/2430;
KM110BH/2470**CHARACTERISTICS**

$T_{amb} = 25\text{ °C}$; $V_{CC} = 5\text{ V}$; $R_L = 1.7\text{ k}\Omega$ and a homogeneous magnetic field $H_{ext} = 100\text{ kA/m}$ in the sensitive layer of the KMZ sensor, unless otherwise specified.

SYMBOL	PARAMETER	CONDITIONS	MIN.	TYP.	MAX.	UNIT
α	angle range: KM110BH/2430 KM110BH/2470	note 1	–	–15 to +15	–	deg
			–	–35 to +35	–	deg
V_O	output voltage range: KM110BH/2430 KM110BH/2470	linear; see Fig.4	–	0.5 to 4.5	–	V
		sinusoidal; see Fig.5	–	0.5 to 4.5	–	V
V_{zero}	zero point voltage	$\alpha = 0^\circ$	–	2.5	–	V
V_{off}	zero point offset voltage: KM110BH/2430 KM110BH/2470	related to sinusoidal sensor characteristic; see Fig.5	–	± 25	–	mV
			–	± 15	–	mV
α_{off}	zero point offset angle	related to hybrid edges; see Fig.7	–	1	3	deg
S	sensitivity: KM110BH/2430 KM110BH/2470	$\alpha = 0^\circ$; note 2	137	140	143	mV/deg
			73	74.5	76	mV/deg
P	precision: KM110BH/2430 KM110BH/2470	–20 to +100 °C	–	0.2	0.5	deg
			–	0.5	1.2	deg
FL	deviation of linearity: KM110BH/2430 KM110BH/2470	note 3	–	± 1	–	%-FS
			–	–	–	%-FS
R_p	reproducibility	$\alpha = 0^\circ$; note 4	–	<0.001	–	deg
R_s	resolution	$\alpha = 0^\circ$; note 5	–	<0.001	–	deg
FH	hysteresis	$\alpha = 0^\circ$; note 6	–	<0.05	–	deg
SP_{max}	maximum angular speed: KM110BH/2430 KM110BH/2470		–	60	–	deg/ms
			–	150	–	deg/ms
R_L	load resistance		1.7	–	–	k Ω
C_L	load capacitance		–	–	10	nF
Temperature coefficients (–40 to +100 °C)						
TCV_{zero}	temperature coefficient of zero point voltage: KM110BH/2430 KM110BH/2470		–	0.2	0.6	mV/K
			–	0.1	0.3	mV/K
TCS	temperature coefficient of sensitivity	–20 to 100 °C	–	100×10^{-6}	–	K $^{-1}$

30° and 70° angle sensor hybrids

KM110BH/2430;
KM110BH/2470**Notes to the characteristics**

1. Refer to Fig.3. The magnetic field $H_{\text{ext}} = 100 \text{ kA/m}$ can be achieved using the magnets listed in Table 1.
2. The sensitivity will change slightly with +0.33% per 10% magnetic field increase if H_{ext} deviates from 100 kA/m.
3. Deviation from best straight line in angle range.
4. Difference in output signal (expressed in degrees) between two zero point ($\alpha = 0^\circ$) measurements, in which the zero point is approached from the same side of the measuring range (e.g. cycle: $+15^\circ \Rightarrow 0^\circ \Rightarrow +15^\circ \Rightarrow 0^\circ$).
5. The smallest detectable change of angle $\Delta\alpha$ for $\alpha = 0^\circ$ (cycle: $0^\circ \Rightarrow \Delta\alpha$).
6. As note 4, but with the zero point being approached from the upper end and lower end of the measuring range respectively (cycle: $+15^\circ \Rightarrow 0^\circ \Rightarrow -15^\circ \Rightarrow 0^\circ$).

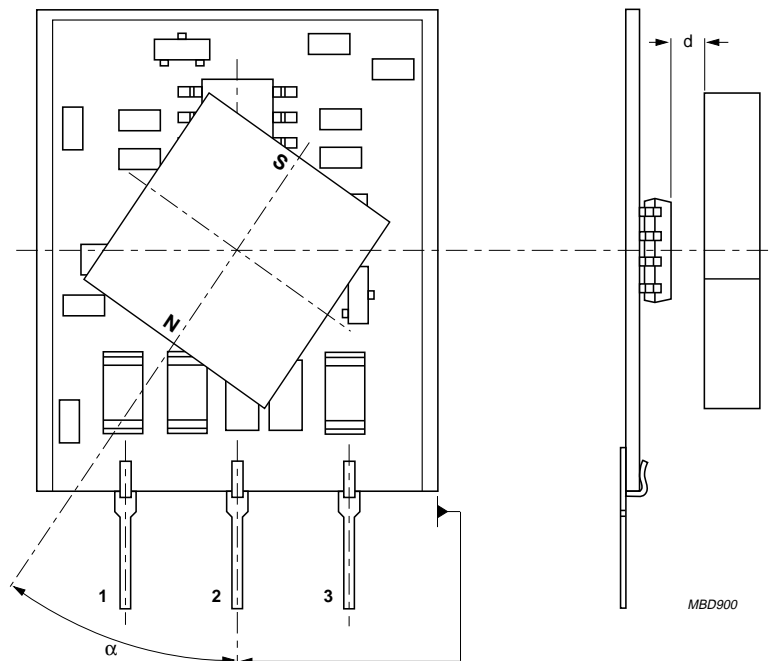

Fig.3 Optimum magnet position relative to the sensor module.

30° and 70° angle sensor hybrids

KM110BH/2430;
KM110BH/2470

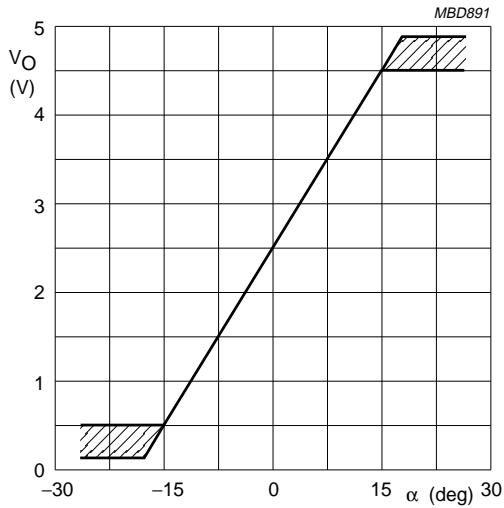

Fig.4 KM110BH/2430 output signal as a function of angle position.

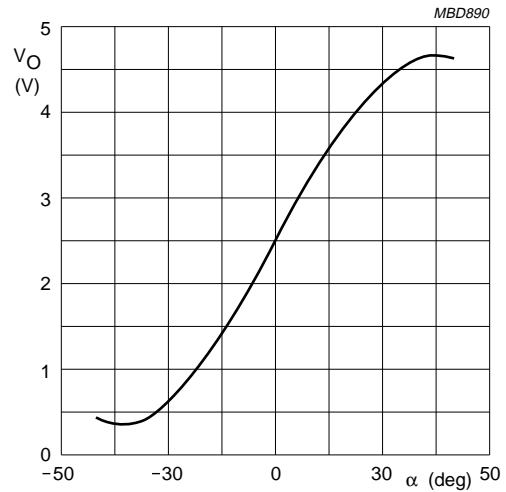
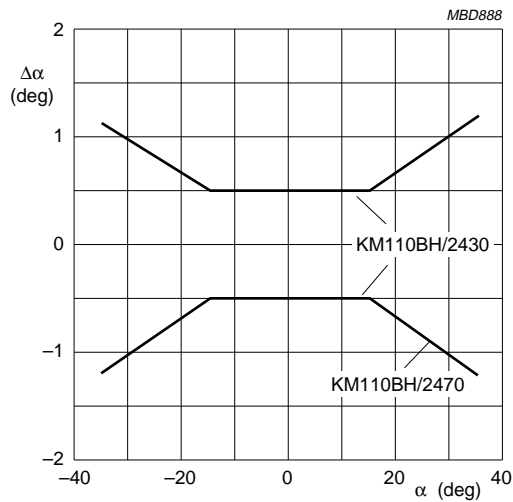

Fig.5 KM110BH/2470 output signal as a function of angle position.



$T_{amb} = -25$ to $+85^\circ\text{C}$.
 $\alpha = 0^\circ$ for $T_{amb} = 25^\circ\text{C}$ and $V_O = 2.5$ V.
 $\Delta\alpha$ increases by a factor 2 in the temperature range:
 $V_O = 2.5 + 2.128 \times \sin(2\alpha)$ for $-36.5^\circ \leq \alpha \leq +36.5^\circ$.
 $T_{amb} = 25^\circ\text{C}$; $V_{CC} = 5$ V; $H_{ext} = 100$ kA/m.

Fig.6 Maximum angle error $\Delta\alpha$ as a function of the angle position.

30° and 70° angle sensor hybrids

KM110BH/2430;
KM110BH/2470

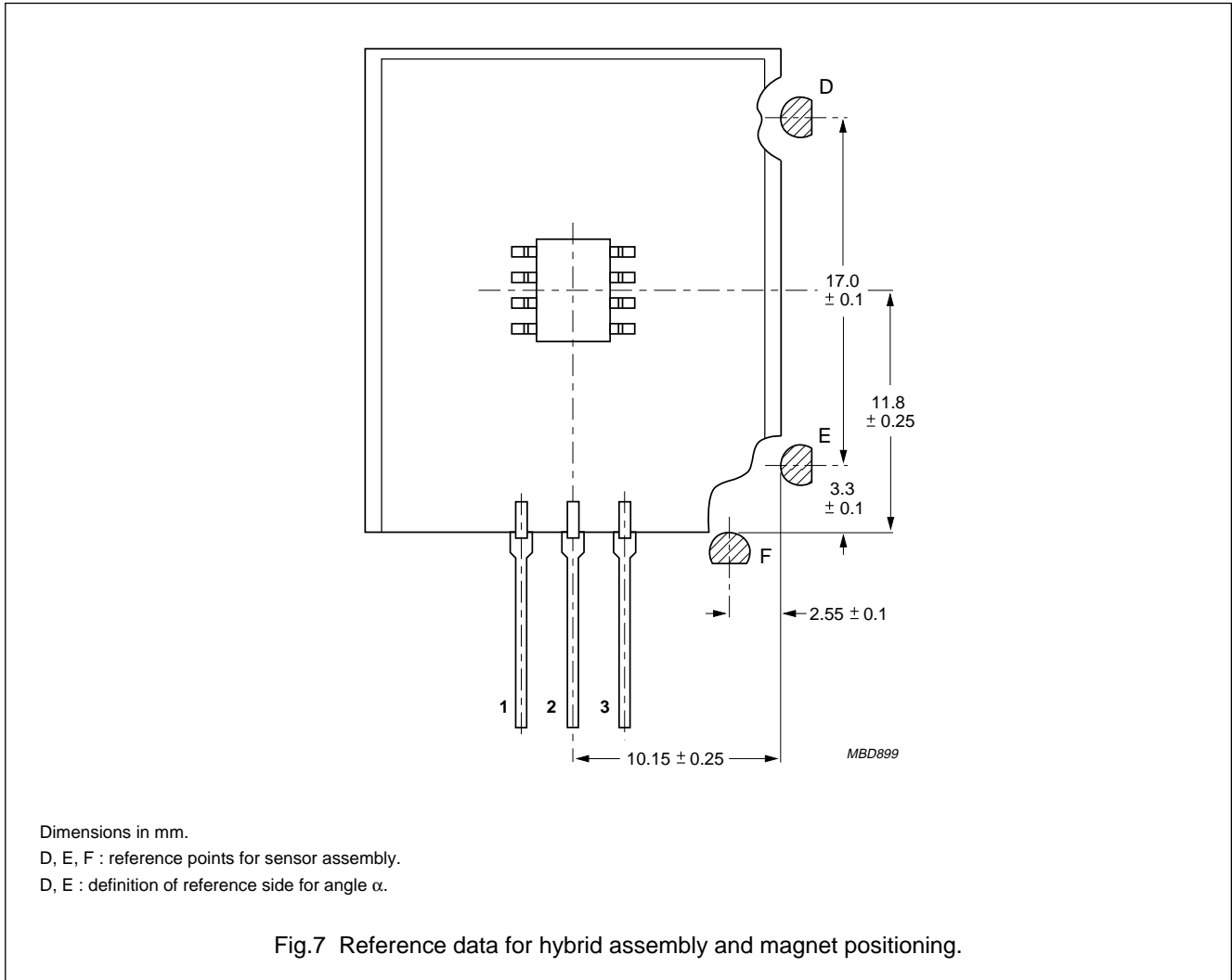

Table 1 Magnets for angle sensor hybrid

MATERIAL	DIMENSIONS ⁽¹⁾ (mm)	d ⁽²⁾ (mm)	TOLERANCE ⁽³⁾ d (mm)	ECCENTRICITY ⁽⁴⁾ (mm)	T _{amb} (°C)
Sm ₂ Co ₁₇	11.2 × 5.5 × 8	2.1	±0.30	±0.25	-55 to +125
	6 × 3 × 5	0.7	±0.15	±0.15	
	8 × 3 × 7.5	0.5	±0.30	±0.20	

Notes

1. The magnetization is always parallel to the latter dimensions given.
2. Distance (d) between magnet and KMZ sensor front as shown in Fig.3.
3. Maximum deviation of distance (d) for which the change in sensor output signal is smaller than 0.5% of full scale sensor signal.
4. Maximum deviation of magnet rotational axis to sensor rotational axis for which the change in sensor output signal is smaller than 0.5% of full scale sensor signal.

30° and 70° angle sensor hybrids

KM110BH/2430;
KM110BH/2470**APPLICATION INFORMATION**

The sensor hybrids KM110BH/2430 and KM110BH/2470 are available with different electrical contacts:

1. Stretched pins with a pitch of 2.54 mm; these pins are recommended for connector and/or cable connections (see Fig.9).
2. Double 's' bent pins (see Fig.10) with a pitch of 5.71 mm; bent pins are recommended for rigid soldered connections to compensate for mechanical stress. Quote type numbers KM110BH/2430G and KM110BH/2470G respectively for these hybrids.

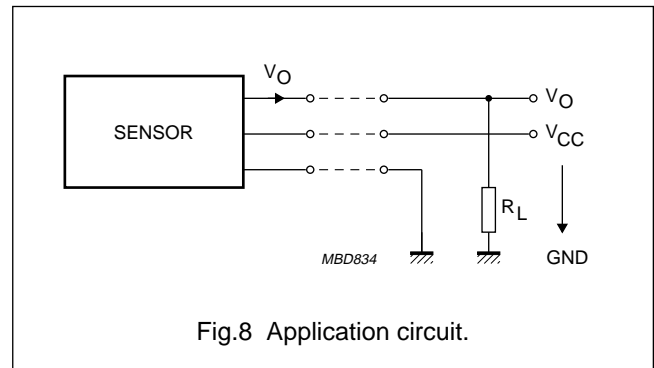

30° and 70° angle sensor hybrids

KM110BH/2430;
KM110BH/2470

PACKAGE OUTLINES

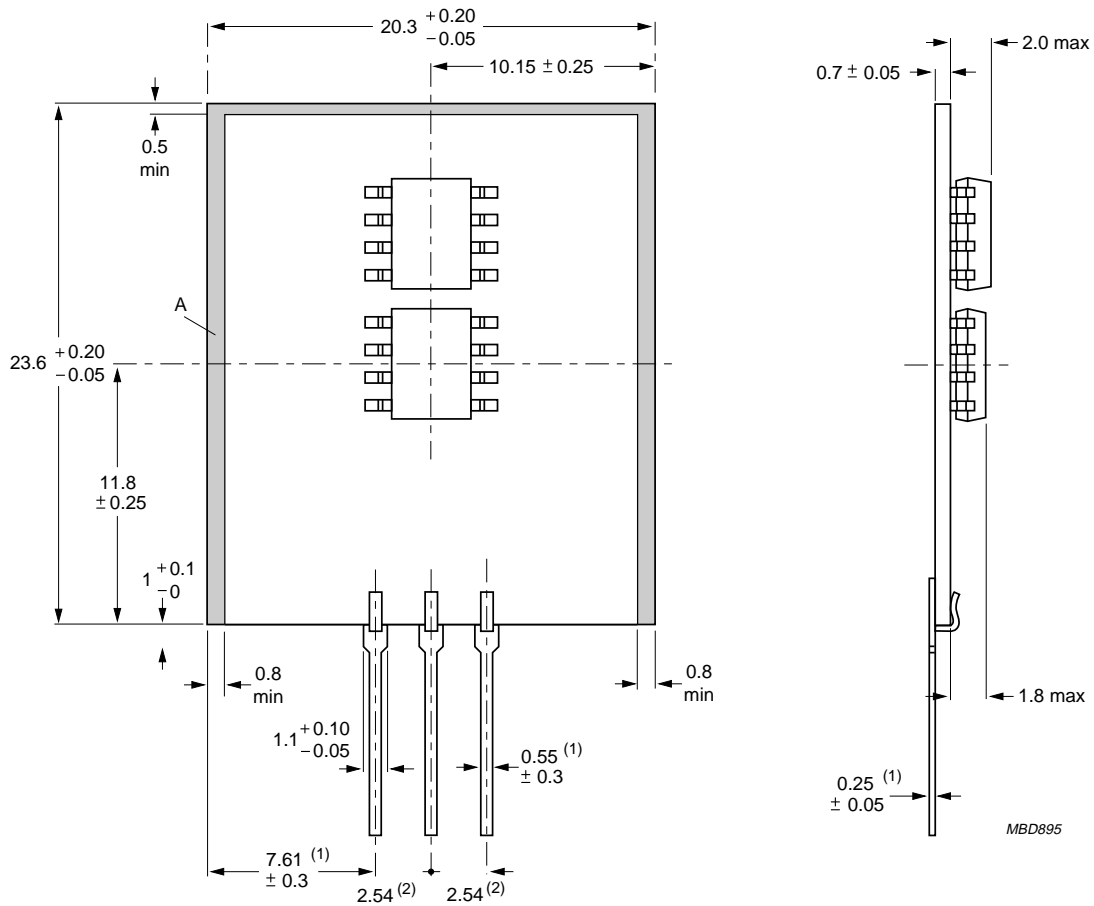

Dimensions in mm.

Area 'A' free of SMD devices.

(1) Dimension before bath soldering, maximum dimension after bath soldering: \varnothing 0.7 mm.

(2) Pitch tolerance: \pm 0.2 mm.

Fig.9 Outline of KM110BH/2430 and KM110BH/2470.

30° and 70° angle sensor hybrids

KM110BH/2430;
KM110BH/2470

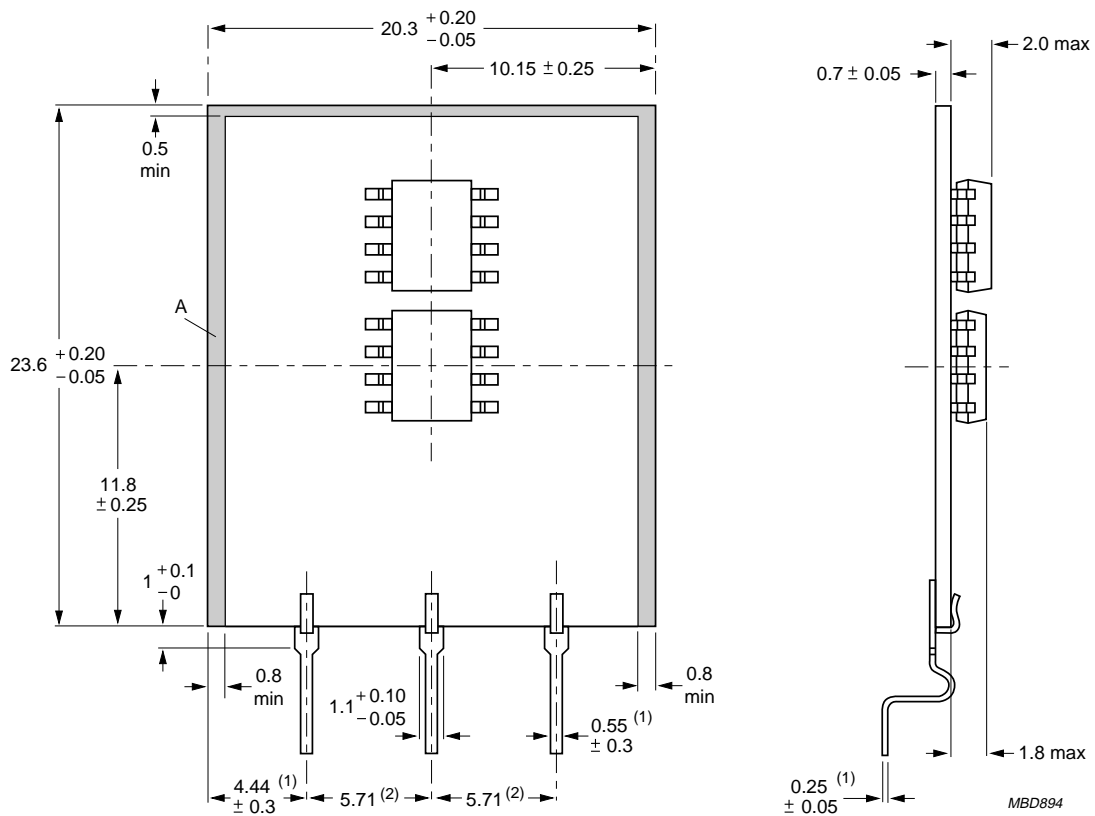

Dimensions in mm.

Area 'A' free of SMD devices.

(1) Dimension before bath soldering, maximum dimension after bath soldering: \varnothing 0.7 mm.

(2) Pitch tolerance: \pm 0.2 mm.

Fig.10 Outline of KM110BH/2430G and KM110BH/2470G.

30° and 70° angle sensor hybrids

KM110BH/2430;
KM110BH/2470**DEFINITIONS**

Data Sheet Status	
Objective specification	This data sheet contains target or goal specifications for product development.
Preliminary specification	This data sheet contains preliminary data; supplementary data may be published later.
Product specification	This data sheet contains final product specifications.
Limiting values	
Limiting values given are in accordance with the Absolute Maximum Rating System (IEC 134). Stress above one or more of the limiting values may cause permanent damage to the device. These are stress ratings only and operation of the device at these or at any other conditions above those given in the Characteristics sections of the specification is not implied. Exposure to limiting values for extended periods may affect device reliability.	
Application information	
Where application information is given, it is advisory and does not form part of the specification.	

LIFE SUPPORT APPLICATIONS

These products are not designed for use in life support appliances, devices, or systems where malfunction of these products can reasonably be expected to result in personal injury. Philips customers using or selling these products for use in such applications do so at their own risk and agree to fully indemnify Philips for any damages resulting from such improper use or sale.

Philips Semiconductors – a worldwide company

Argentina: see South America

Australia: 34 Waterloo Road, NORTH RYDE, NSW 2113,
Tel. +61 2 9805 4455, Fax. +61 2 9805 4466

Austria: Computerstr. 6, A-1101 WIEN, P.O. Box 213,
Tel. +43 1 60 101, Fax. +43 1 60 101 1210

Belarus: Hotel Minsk Business Center, Bld. 3, r. 1211, Volodarski Str. 6,
220050 MINSK, Tel. +375 172 200 733, Fax. +375 172 200 773

Belgium: see The Netherlands

Brazil: see South America

Bulgaria: Philips Bulgaria Ltd., Energoproject, 15th floor,
51 James Bourchier Blvd., 1407 SOFIA,
Tel. +359 2 689 211, Fax. +359 2 689 102

Canada: PHILIPS SEMICONDUCTORS/COMPONENTS,
Tel. +1 800 234 7381

China/Hong Kong: 501 Hong Kong Industrial Technology Centre,
72 Tat Chee Avenue, Kowloon Tong, HONG KONG,
Tel. +852 2319 7888, Fax. +852 2319 7700

Colombia: see South America

Czech Republic: see Austria

Denmark: Prags Boulevard 80, PB 1919, DK-2300 COPENHAGEN S,
Tel. +45 32 88 2636, Fax. +45 31 57 1949

Finland: Sinikalliontie 3, FIN-02630 ESPOO,
Tel. +358 9 615800, Fax. +358 9 61580/xxx

France: 4 Rue du Port-aux-Vins, BP317, 92156 SURESNES Cedex,
Tel. +33 1 40 99 6161, Fax. +33 1 40 99 6427

Germany: Hammerbrookstraße 69, D-20097 HAMBURG,
Tel. +49 40 23 53 60, Fax. +49 40 23 536 300

Greece: No. 15, 25th March Street, GR 17778 TAVROS/ATHENS,
Tel. +30 1 4894 339/239, Fax. +30 1 4814 240

Hungary: see Austria

India: Philips INDIA Ltd, Shivsagar Estate, A Block, Dr. Annie Besant Rd.
Worli, MUMBAI 400 018, Tel. +91 22 4938 541, Fax. +91 22 4938 722

Indonesia: see Singapore

Ireland: Newstead, Clonskeagh, DUBLIN 14,
Tel. +353 1 7640 000, Fax. +353 1 7640 200

Israel: RAPAC Electronics, 7 Kehilat Saloniki St, TEL AVIV 61180,
Tel. +972 3 645 0444, Fax. +972 3 649 1007

Italy: PHILIPS SEMICONDUCTORS, Piazza IV Novembre 3,
20124 MILANO, Tel. +39 2 6752 2531, Fax. +39 2 6752 2557

Japan: Philips Bldg 13-37, Kohnan 2-chome, Minato-ku, TOKYO 108,
Tel. +81 3 3740 5130, Fax. +81 3 3740 5077

Korea: Philips House, 260-199 Itaewon-dong, Yongsan-ku, SEOUL,
Tel. +82 2 709 1412, Fax. +82 2 709 1415

Malaysia: No. 76 Jalan Universiti, 46200 PETALING JAYA, SELANGOR,
Tel. +60 3 750 5214, Fax. +60 3 757 4880

Mexico: 5900 Gateway East, Suite 200, EL PASO, TEXAS 79905,
Tel. +9-5 800 234 7381

Middle East: see Italy

Netherlands: Postbus 90050, 5600 PB EINDHOVEN, Bldg. VB,
Tel. +31 40 27 82785, Fax. +31 40 27 88399

New Zealand: 2 Wagener Place, C.P.O. Box 1041, AUCKLAND,
Tel. +64 9 849 4160, Fax. +64 9 849 7811

Norway: Box 1, Manglerud 0612, OSLO,
Tel. +47 22 74 8000, Fax. +47 22 74 8341

Philippines: Philips Semiconductors Philippines Inc.,
106 Valero St. Salcedo Village, P.O. Box 2108 MCC, MAKATI,
Metro MANILA, Tel. +63 2 816 6380, Fax. +63 2 817 3474

Poland: Ul. Lukiska 10, PL 04-123 WARSZAWA,
Tel. +48 22 612 2831, Fax. +48 22 612 2327

Portugal: see Spain

Romania: see Italy

Russia: Philips Russia, Ul. Usatcheva 35A, 119048 MOSCOW,
Tel. +7 095 247 9145, Fax. +7 095 247 9144

Singapore: Lorong 1, Toa Payoh, SINGAPORE 1231,
Tel. +65 350 2538, Fax. +65 251 6500

Slovakia: see Austria

Slovenia: see Italy

South Africa: S.A. PHILIPS Pty Ltd., 195-215 Main Road Martindale,
2092 JOHANNESBURG, P.O. Box 7430 Johannesburg 2000,
Tel. +27 11 470 5911, Fax. +27 11 470 5494

South America: Rua do Rocio 220, 5th floor, Suite 51,
04552-903 São Paulo, SÃO PAULO - SP, Brazil,
Tel. +55 11 821 2333, Fax. +55 11 829 1849

Spain: Balmes 22, 08007 BARCELONA,
Tel. +34 3 301 6312, Fax. +34 3 301 4107

Sweden: Kottbygatan 7, Akalla, S-16485 STOCKHOLM,
Tel. +46 8 632 2000, Fax. +46 8 632 2745

Switzerland: Allmendstrasse 140, CH-8027 ZÜRICH,
Tel. +41 1 488 2686, Fax. +41 1 481 7730

Taiwan: PHILIPS TAIWAN Ltd., 23-30F, 66,
Chung Hsiao West Road, Sec. 1, P.O. Box 22978,
TAIPEI 100, Tel. +886 2 382 4443, Fax. +886 2 382 4444

Thailand: PHILIPS ELECTRONICS (THAILAND) Ltd.,
209/2 Sanpavuth-Bangna Road Prakanong, BANGKOK 10260,
Tel. +66 2 745 4090, Fax. +66 2 398 0793

Turkey: Talatpasa Cad. No. 5, 80640 GÜLTEPE/ISTANBUL,
Tel. +90 212 279 2770, Fax. +90 212 282 6707

Ukraine: PHILIPS UKRAINE, 4 Patrice Lumumba str., Building B, Floor 7,
252042 KIEV, Tel. +380 44 264 2776, Fax. +380 44 268 0461

United Kingdom: Philips Semiconductors Ltd., 276 Bath Road, Hayes,
MIDDLESEX UB3 5BX, Tel. +44 181 730 5000, Fax. +44 181 754 8421

United States: 811 East Arques Avenue, SUNNYVALE, CA 94088-3409,
Tel. +1 800 234 7381

Uruguay: see South America

Vietnam: see Singapore

Yugoslavia: PHILIPS, Trg N. Pasica 5/v, 11000 BEOGRAD,
Tel. +381 11 625 344, Fax. +381 11 635 777

For all other countries apply to: Philips Semiconductors, Marketing & Sales Communications,
Building BE-p, P.O. Box 218, 5600 MD EINDHOVEN, The Netherlands, Fax. +31 40 27 24825

Internet: <http://www.semiconductors.philips.com>

© Philips Electronics N.V. 1996

SCA52

All rights are reserved. Reproduction in whole or in part is prohibited without the prior written consent of the copyright owner.

The information presented in this document does not form part of any quotation or contract, is believed to be accurate and reliable and may be changed without notice. No liability will be accepted by the publisher for any consequence of its use. Publication thereof does not convey nor imply any license under patent- or other industrial or intellectual property rights.

Printed in The Netherlands

147021/1200/02/pp12

Date of release: 1996 Nov 08

Document order number: 9397 750 01125

Let's make things better.

**Philips
Semiconductors**



PHILIPS