

LM4041

Precision Micropower Shunt Voltage Reference

General Description

Ideal for space critical applications, the LM4041 precision voltage reference is available in the sub-miniature SC70 and SOT-23 surface-mount packages. The LM4041's advanced design eliminates the need for an external stabilizing capacitor while ensuring stability with any capacitive load, thus making the LM4041 easy to use. Further reducing design effort is the availability of a fixed (1.225V) and adjustable reverse breakdown voltage. The minimum operating current is 60 μ A for the LM4041-1.2 and the LM4041-ADJ. Both versions have a maximum operating current of 12 mA.

The LM4041 utilizes fuse and zener-zap reverse breakdown or reference voltage trim during wafer sort to ensure that the prime parts have an accuracy of better than $\pm 0.1\%$ (A grade) at 25°C. Bandgap reference temperature drift curvature correction and low dynamic impedance ensure stable reverse breakdown voltage accuracy over a wide range of operating temperatures and currents.

Features

- Small packages: SOT-23, TO-92, and SC70
- No output capacitor required
- Tolerates capacitive loads
- Reverse breakdown voltage options of 1.225V and adjustable

Key Specifications (LM4041-1.2)

- | | |
|--|--------------------|
| ■ Output voltage tolerance (A grade, 25°C) | $\pm 0.1\%$ (max) |
| ■ Low output noise (10 Hz to 10kHz) | $20\mu V_{rms}$ |
| ■ Wide operating current range | 60 μ A to 12mA |
| ■ Industrial temperature range | -40°C to +85°C |
| ■ Extended temperature range | -40°C to +125°C |
| ■ Low temperature coefficient | 100 ppm/°C (max) |

Applications

- Portable, Battery-Powered Equipment
- Data Acquisition Systems
- Instrumentation
- Process Control
- Energy Management
- Automotive
- Precision Audio Components

Connection Diagrams

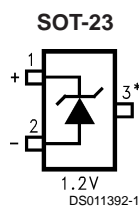

*This pin must be left floating or connected to pin 2.

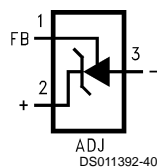

Top View

See NS Package Number MF03A
(JEDEC Registration TO-236AB)

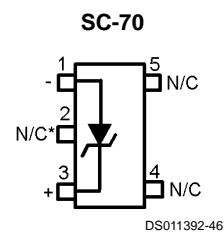

*This pin must be left floating or connected to pin 1.

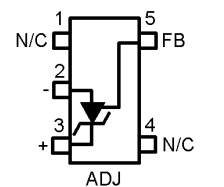

Top View

See NS Package Number MAA05A

Connection Diagrams (Continued)

TO-92

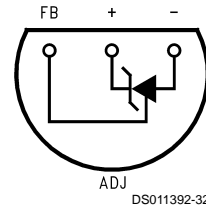
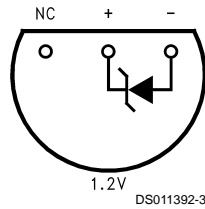

Bottom View
See NS Package Number Z03A

Ordering Information

Reverse Breakdown Voltage Tolerance at 25°C and Average Reverse Breakdown Voltage Temperature Coefficient	Package					NS Package Number
	M3 (SOT-23)		M7 (SC70)		Z (TO-92)	
	Supplied as 1000 Units Tape and Reel	Supplied as 3000 Units Tape and Reel	Supplied as 1000 Units Tape and Reel	Supplied as 3000 Units Tape and Reel		
±0.1%, 100 ppm/°C max (A grade)	LM4041AIM3-1.2	LM4041AIM3X-1.2			LM4041AIZ-1.2	MF03A, Z03A
±0.2%, 100 ppm/°C max (B grade)	LM4041BIM3-1.2	LM4041BIM3X-1.2	LM4041BIM7-1.2	LM4041BIM7X-1.2	LM4041BIZ-1.2	MF03A, Z03A, MAA05A
±0.5%, 100 ppm/°C max (C grade)	LM4041CEM3-1.2 LM4041CIM3-1.2 LM4041CEM3-ADJ LM4041CIM3-ADJ	LM4041CEM3X-1.2 LM4041CIM3X-1.2 LM4041CEM3X-ADJ LM4041CIM3X-ADJ	LM4041CIM7-1.2 LM4041CIM7-ADJ	LM4041CIM7X-1.2 LM4041CIM7X-ADJ	LM4041CIZ-1.2 LM4041CIZ-ADJ	MF03A, Z03A, MAA05A
±1.0%, 150 ppm/°C max (D grade)	LM4041DEM3-1.2 LM4041DIM3-1.2 LM4041DEM3-ADJ LM4041DIM3-ADJ	LM4041DEM3X-1.2 LM4041DIM3X-1.2 LM4041DEM3X-ADJ LM4041DIM3X-ADJ	LM4041DIM7-1.2 LM4041DIM7-ADJ	LM4041DIM7X-1.2 LM4041DIM7X-ADJ	LM4041DIZ-1.2 LM4041DIZ-ADJ	MF03A, Z03A, MAA05A
±2.0%, 150 ppm/°C max (E grade)	LM4041EEM3-1.2 LM4041EIM3-1.2	LM4041EEM3X-1.2 LM4041EIM3X-1.2	LM4041EIM7-1.2	LM4041EIM7X-1.2	LM4041EIZ-1.2	MF03A, Z03A, MAA05A

SOT-23 and SC70 Package Marking Information

Only three fields of marking are possible on the SOT-23's and SC70's small surface. This table gives the meaning of the three fields.

Part Marking	Field Definition
R1A (SOT-23 Only)	First Field: R = Reference
R1B	Second Field: 1 = 1.225V Voltage Option
R1C	A = Adjustable
R1D	Third Field: A-E = Initial Reverse Breakdown
R1E	Voltage or Reference Voltage Tolerance A = ±0.1%, B = ±0.2%, C = ±0.5%, D = ±1.0%, E = ±2.0%
RAC	
RAD	

Absolute Maximum Ratings (Note 1)

If Military/Aerospace specified devices are required, please contact the National Semiconductor Sales Office/Distributors for availability and specifications.

Reverse Current	20 mA
Forward Current	10 mA
Maximum Output Voltage (LM4041-ADJ)	15V
Power Dissipation ($T_A = 25^\circ\text{C}$) (Note 2)	
M3 Package	306 mW
Z Package	550 mW
M7 Package	241mW
Storage Temperature	-65°C to $+150^\circ\text{C}$
Lead Temperature	
M3 Packages	
Vapor phase (60 seconds)	$+215^\circ\text{C}$
Infrared (15 seconds)	$+220^\circ\text{C}$
Z Package	

Soldering (10 seconds)	$+260^\circ\text{C}$
ESD Susceptibility	
Human Body Model (Note 3)	2 kV
Machine Model (Note 3)	200V

See AN-450 "Surface Mounting Methods and Their Effect on Product Reliability" for other methods of soldering surface mount devices.

Operating Ratings (Notes 1, 2)

Temperature Range	$(T_{\min} \leq T_A \leq T_{\max})$
Industrial Temperature Range	$-40^\circ\text{C} \leq T_A \leq +85^\circ\text{C}$
Extended Temperature Range	$-40^\circ\text{C} \leq T_A \leq +125^\circ\text{C}$
Reverse Current	
LM4041-1.2	60 μA to 12 mA
LM4041-ADJ	60 μA to 12 mA
Output Voltage Range	
LM4041-ADJ	1.24V to 10V

LM4041-1.2

Electrical Characteristics (Industrial Temperature Range)

Boldface limits apply for $T_A = T_J = T_{\min}$ to T_{\max} ; all other limits $T_A = T_J = 25^\circ\text{C}$. The grades A and B designate initial Reverse Breakdown Voltage tolerances of $\pm 0.1\%$ and $\pm 0.2\%$, respectively.

Symbol	Parameter	Conditions	Typical (Note 4)	LM4041AIM3 LM4041AIZ Limits (Note 5)	LM4041BIM3 LM4041BIZ LM4041BIM7 Limits (Note 5)	Units (Limit)	
V_R	Reverse Breakdown Voltage	$I_R = 100 \mu\text{A}$	1.225			V	
	Reverse Breakdown Voltage Tolerance (Note 6)	$I_R = 100 \mu\text{A}$		± 1.2 ± 9.2	± 2.4 ± 10.4	mV (max) mV (max)	
$I_{R\text{MIN}}$	Minimum Operating Current		45	60 65	60 65	μA μA (max) μA (max)	
		$\Delta V_R/\Delta T$	Average Reverse Breakdown Voltage Temperature Coefficient (Note 6)	$I_R = 10 \text{ mA}$ $I_R = 1 \text{ mA}$ $I_R = 100 \mu\text{A}$	± 20 ± 15 ± 15	± 100 ± 100	ppm/ $^\circ\text{C}$ ppm/ $^\circ\text{C}$ (max) ppm/ $^\circ\text{C}$
		$\Delta V_R/\Delta I_R$	Reverse Breakdown Voltage Change with Operating Current Change	$I_{R\text{MIN}} \leq I_R \leq 1 \text{ mA}$ $1 \text{ mA} \leq I_R \leq 12 \text{ mA}$	0.7 4.0	1.5 2.0 6.0 8.0	1.5 2.0 6.0 8.0
Z_R	Reverse Dynamic Impedance	$I_R = 1 \text{ mA}$, $f = 120 \text{ Hz}$, $I_{AC} = 0.1 I_R$	0.5	1.5	1.5	Ω Ω (max)	
		$I_R = 100 \mu\text{A}$ $10 \text{ Hz} \leq f \leq 10 \text{ kHz}$	20			μV_{rms}	
ΔV_R	Reverse Breakdown Voltage Long Term Stability	$t = 1000 \text{ hrs}$ $T = 25^\circ\text{C} \pm 0.1^\circ\text{C}$ $I_R = 100 \mu\text{A}$	120			ppm	

LM4041-1.2 Electrical Characteristics (Industrial Temperature Range)

Boldface limits apply for $T_A = T_J = T_{MIN}$ to T_{MAX} ; all other limits $T_A = T_J = 25^\circ\text{C}$. The grades C, D and E designate initial Reverse Breakdown Voltage tolerances of $\pm 0.5\%$, $\pm 1.0\%$ and $\pm 2.0\%$, respectively.

Symbol	Parameter	Conditions	Typical (Note 4)	LM4041CIM3 LM4041CIZ LM4041CIM7 Limits (Note 5)	LM4041DIM3 LM4041DIZ LM4041DIM7 Limits (Note 5)	LM4041EIM3 LM4041EIZ LM4041EIM7 Limits (Note 5)	Units (Limit)
V_R	Reverse Breakdown Voltage	$I_R = 100 \mu\text{A}$	1.225				V
	Reverse Breakdown Voltage Tolerance (Note 6)	$I_R = 100 \mu\text{A}$		± 6	± 12	± 25	mV (max)
				± 14	± 24	± 36	mV (max)
I_{RMIN}	Minimum Operating Current		45				μA
				60	65	65	μA (max)
				65	70	70	μA (max)
$\Delta V_R/\Delta T$	V_R Temperature Coefficient (Note 6)	$I_R = 10 \text{ mA}$	± 20				ppm/ $^\circ\text{C}$
		$I_R = 1 \text{ mA}$	± 15	± 100	± 150	± 150	ppm/ $^\circ\text{C}$ (max)
		$I_R = 100 \mu\text{A}$	± 15				ppm/ $^\circ\text{C}$
$\Delta V_R/I_R$	Reverse Breakdown Voltage Change with Operating Current Change	$I_{RMIN} \leq I_R \leq 1 \text{ mA}$	0.7				mV
				1.5	2.0	2.0	mV (max)
				2.0	2.5	2.5	mV (max)
		$1 \text{ mA} \leq I_R \leq 12 \text{ mA}$	2.5				mV
				6.0	8.0	8.0	mV (max)
				8.0	10.0	10.0	mV (max)
Z_R	Reverse Dynamic Impedance	$I_R = 1 \text{ mA}$, $f = 120 \text{ Hz}$	0.5				Ω
		$I_{AC} = 0.1 I_R$		1.5	2.0	2.0	Ω (max)
e_N	Wideband Noise	$I_R = 100 \mu\text{A}$ $10 \text{ Hz} \leq f \leq 10 \text{ kHz}$	20				μV_{rms}
ΔV_R	Reverse Breakdown Voltage Long Term Stability	$t = 1000 \text{ hrs}$ $T = 25^\circ\text{C} \pm 0.1^\circ\text{C}$ $I_R = 100 \mu\text{A}$	120				ppm

LM4041-1.2 Electrical Characteristics (Extended Temperature Range)

Boldface limits apply for $T_A = T_J = T_{MIN}$ to T_{MAX} ; all other limits $T_A = T_J = 25^\circ\text{C}$. The grades C, D and E designate initial Reverse Breakdown Voltage tolerance of $\pm 0.5\%$, $\pm 1.0\%$ and $\pm 2.0\%$ respectively.

Symbol	Parameter	Conditions	Typical (Note 4)	LM4041CEM3 Limits (Note 5)	LM4041DEM3 Limits (Note 5)	LM4041EEM3 Limits (Note 5)	Units (Limit)	
V_R	Reverse Breakdown Voltage	$I_R = 100 \mu\text{A}$	1.225				V	
	Reverse Breakdown Voltage Error (Note 6)	$I_R = 100 \mu\text{A}$		± 6 ± 18.4	± 12 ± 31	± 25 ± 43	mV (max) mV (max)	
I_{RMIN}	Minimum Operating Current		45	60 68	65 73	65 73	μA μA (max) μA (max)	
		VR Temperature Coefficient (Note 6)	$I_R = 10 \text{ mA}$	± 20	± 100	± 150	± 150	ppm/ $^\circ\text{C}$
			$I_R = 1 \text{ mA}$	± 15				ppm/ $^\circ\text{C}$ (max)
$\Delta V_R / \Delta I_R$	Reverse Breakdown Change with Current	$I_{RMIN} \leq I_R \leq 1.0 \text{ mA}$	0.7	1.5 2.0	2.0 2.5	2.0 2.5	mV mV (max) mV (max)	
		$1 \text{ mA} \leq I_R \leq 12 \text{ mA}$	2.5	6.0 8.0	8.0 10.0	8.0 10.0	mV mV (max) mV (max)	
Z_R	Reverse Dynamic Impedance	$I_R = 1 \text{ mA}$, $f = 120 \text{ Hz}$, $I_{AC} = 0.1 I_R$	0.5	1.5	2.0	2.0	Ω Ω (max)	
e_N	Noise Voltage	$I_R = 100 \mu\text{A}$ $10 \text{ Hz} \leq f \leq 10 \text{ kHz}$	20				μV_{rms}	
ΔV_R	Long Term Stability (Non-Cumulative)	$t = 1000 \text{ hrs}$ $T = 25^\circ\text{C} \pm 0.1^\circ\text{C}$ $I_R = 100 \mu\text{A}$	120				ppm	

LM4041-ADJ (Adjustable) Electrical Characteristics (Industrial Temperature Range)

Boldface limits apply for $T_A = T_J = T_{MIN}$ to T_{MAX} ; all other limits $T_J = 25^\circ\text{C}$ unless otherwise specified (SOT-23, see (Note 7)), $I_{RMIN} \leq I_R \leq 12\text{ mA}$, $V_{REF} \leq V_{OUT} \leq 10\text{V}$. The grades C and D designate initial Reference Voltage Tolerances of $\pm 0.5\%$ and $\pm 1\%$, respectively for $V_{OUT} = 5\text{V}$.

Symbol	Parameter	Conditions	Typical (Note 4)	LM4041CIM3 LM4041CIZ LM4041CIM7 (Note 5)	LM4041DIM3 LM4041DIZ LM4041DIM7 (Note 5)	Units (Limit)
V_{REF}	Reference Voltage	$I_R = 100\ \mu\text{A}$, $V_{OUT} = 5\text{V}$	1.233			V
	Reference Voltage Tolerance (Note 8)	$I_R = 100\ \mu\text{A}$, $V_{OUT} = 5\text{V}$		± 6.2 ± 14	± 12 ± 24	mV (max) mV (max)
I_{RMIN}	Minimum Operating Current		45	60 65	65 70	μA μA (max) μA (max)
$\Delta V_{REF}/\Delta I_R$	Reference Voltage Change with Operating Current Change	$I_{RMIN} \leq I_R \leq 1\text{ mA}$ SOT-23: $V_{OUT} \geq 1.6\text{V}$ (Note 7)	0.7	1.5 2.0	2.0 2.5	mV mV (max) mV (max)
		$1\text{ mA} \leq I_R \leq 12\text{ mA}$ SOT-23: $V_{OUT} \geq 1.6\text{V}$ (Note 7)	2	4 6	6 8	mV mV (max) mV (max)
$\Delta V_{REF}/\Delta V_O$	Reference Voltage Change with Output Voltage Change	$I_R = 1\text{ mA}$	-1.55	-2.0 -2.5	-2.5 -3.0	mV/V mV/V (max) mV/V (max)
I_{FB}	Feedback Current		60	100 120	150 200	nA nA (max) nA (max)
$\Delta V_{REF}/\Delta T$	Average Reference Voltage Temperature Coefficient (Note 8)	$V_{OUT} = 5\text{V}$, $I_R = 10\text{ mA}$	20	± 100	± 150	ppm/ $^\circ\text{C}$
		$I_R = 1\text{ mA}$	15			ppm/ $^\circ\text{C}$ (max)
		$I_R = 100\ \mu\text{A}$	15			ppm/ $^\circ\text{C}$
Z_{OUT}	Dynamic Output Impedance	$I_R = 1\text{ mA}$, $f = 120\text{ Hz}$, $I_{AC} = 0.1 I_R$				
		$V_{OUT} = V_{REF}$ $V_{OUT} = 10\text{V}$	0.3 2			Ω Ω
e_N	Wideband Noise	$I_R = 100\ \mu\text{A}$, $V_{OUT} = V_{REF}$ $10\text{ Hz} \leq f \leq 10\text{ kHz}$	20			μV_{rms}
ΔV_{REF}	Reference Voltage Long Term Stability	$t = 1000\text{ hrs}$, $I_R = 100\ \mu\text{A}$ $T = 25^\circ\text{C} \pm 0.1^\circ\text{C}$	120			ppm

LM4041-ADJ (Adjustable) Electrical Characteristics (Extended Temperature Range)

Boldface limits apply for $T_A = T_J = T_{MIN}$ to T_{MAX} ; all other limits $T_J = 25^\circ\text{C}$ unless otherwise specified (SOT-23, see (Note 7)), $I_{RMIN} \leq I_R \leq 12\text{ mA}$, $V_{REF} \leq V_{OUT} \leq 10\text{V}$. The grades C and D designate initial Reference Voltage Tolerances of $\pm 0.5\%$ and $\pm 1\%$, respectively for $V_{OUT} = 5\text{V}$.

Symbol	Parameter	Conditions	Typical (Note 4)	LM4041CEM3 (Note 5)	LM4041DEM3 (Note 5)	Units (Limit)	
V_{REF}	Reference Voltage	$I_R = 100\ \mu\text{A}$, $V_{OUT} = 5\text{V}$	1.233			V	
	Reference Voltage Tolerance (Note 8)	$I_R = 100\ \mu\text{A}$, $V_{OUT} = 5\text{V}$		± 6.2 ± 18	± 12 ± 30	mV (max) mV (max)	
I_{RMIN}	Minimum Operating Current		45	60 68	65 73	μA μA (max) μA (max)	
		Reference Voltage Change with Operating Current Change	$I_{RMIN} \leq I_R \leq 1\text{ mA}$ SOT-23: $V_{OUT} \geq 1.6\text{V}$ (Note 7)	0.7	1.5 2.0	2.0 2.5	mV mV (max) mV (max)
			$1\text{ mA} \leq I_R \leq 12\text{ mA}$ SOT-23: $V_{OUT} \geq 1.6\text{V}$ (Note 7)	2	8 6	10 8	mV mV (max) mV (max)
$\Delta V_{REF}/\Delta V_O$	Reference Voltage Change with Output Voltage Change	$I_R = 1\text{ mA}$	-1.55	-2.0 -3.0	-2.5 -4.0	mV/V mV/V (max) mV/V (max)	
I_{FB}	Feedback Current		60	100 120	150 200	nA nA (max) nA (max)	
$\Delta V_{REF}/\Delta T$	Average Reference Voltage Temperature Coefficient (Note 8)	$V_{OUT} = 5\text{V}$, $I_R = 10\text{ mA}$	20	± 100	± 150	ppm/ $^\circ\text{C}$	
		$I_R = 1\text{ mA}$	15			ppm/ $^\circ\text{C}$ (max)	
		$I_R = 100\ \mu\text{A}$	15			ppm/ $^\circ\text{C}$	
Z_{OUT}	Dynamic Output Impedance	$I_R = 1\text{ mA}$, $f = 120\text{ Hz}$, $I_{AC} = 0.1 I_R$	$V_{OUT} = V_{REF}$	0.3		Ω	
			$V_{OUT} = 10\text{V}$	2		Ω	
e_N	Wideband Noise	$I_R = 100\ \mu\text{A}$ $V_{OUT} = V_{REF}$ $10\text{ Hz} \leq f \leq 10\text{ kHz}$	20			μV_{rms}	
ΔV_{REF}	Reference Voltage Long Term Stability	$t = 1000\text{ hrs}$, $I_R = 100\ \mu\text{A}$ $T = 25^\circ\text{C} \pm 0.1^\circ\text{C}$	120			ppm	

Electrical Characteristics (continued)

Note 1: Absolute Maximum Ratings indicate limits beyond which damage to the device may occur. Operating Ratings indicate conditions for which the device is functional, but do not guarantee specific performance limits. For guaranteed specifications and test conditions, see the Electrical Characteristics. The guaranteed specifications apply only for the test conditions listed. Some performance characteristics may degrade when the device is not operated under the listed test conditions.

Note 2: The maximum power dissipation must be derated at elevated temperatures and is dictated by T_{Jmax} (maximum junction temperature), θ_{JA} (junction to ambient thermal resistance), and T_A (ambient temperature). The maximum allowable power dissipation at any temperature is $PD_{max} = (T_{Jmax} - T_A)/\theta_{JA}$ or the number given in the Absolute Maximum Ratings, whichever is lower. For the LM4041, $T_{Jmax} = 125^\circ\text{C}$, and the typical thermal resistance (θ_{JA}), when board mounted, is 326°C/W for the SOT-23 package, 415°C/W for the SC70 package and 180°C/W with 0.4" lead length and 170°C/W with 0.125" lead length for the TO-92 package.

Note 3: The human body model is a 100 pF capacitor discharged through a 1.5 k Ω resistor into each pin. The machine model is a 200 pF capacitor discharged directly into each pin. All pins are rated at 2kV for Human Body Model, but the feedback pin which is rated at 1kV.

Note 4: Typical values are at $T_J = 25^\circ\text{C}$ and represent most likely parametric norm.

Note 5: Limits are 100% production tested at 25°C . Limits over temperature are guaranteed through correlation using Statistical Quality Control (SQC) methods. The limits are used to calculate National's AOQL.

Note 6: The boldface (over-temperature) limit for Reverse Breakdown Voltage Tolerance is defined as the room temperature Reverse Breakdown Voltage Tolerance $\pm[(\Delta V_R/\Delta T)(\max \Delta T)(V_R)]$. Where, $\Delta V_R/\Delta T$ is the V_R temperature coefficient, $\max \Delta T$ is the maximum difference in temperature from the reference point of 25°C to T_{MAX} or T_{MIN} , and V_R is the reverse breakdown voltage. The total over-temperature tolerance for the different grades in the industrial temperature range where $\max \Delta T = 65^\circ\text{C}$ is shown below:

A-grade: $\pm 0.75\% = \pm 0.1\% \pm 100 \text{ ppm}/^\circ\text{C} \times 65^\circ\text{C}$

B-grade: $\pm 0.85\% = \pm 0.2\% \pm 100 \text{ ppm}/^\circ\text{C} \times 65^\circ\text{C}$

C-grade: $\pm 1.15\% = \pm 0.5\% \pm 100 \text{ ppm}/^\circ\text{C} \times 65^\circ\text{C}$

D-grade: $\pm 1.98\% = \pm 1.0\% \pm 150 \text{ ppm}/^\circ\text{C} \times 65^\circ\text{C}$

E-grade: $\pm 2.98\% = \pm 2.0\% \pm 150 \text{ ppm}/^\circ\text{C} \times 65^\circ\text{C}$

The total over-temperature tolerance for the different grades in the extended temperature range where $\max \Delta T = 100^\circ\text{C}$ is shown below:

B-grade: $\pm 1.2\% = \pm 0.2\% \pm 100 \text{ ppm}/^\circ\text{C} \times 100^\circ\text{C}$

C-grade: $\pm 1.5\% = \pm 0.5\% \pm 100 \text{ ppm}/^\circ\text{C} \times 100^\circ\text{C}$

D-grade: $\pm 2.5\% = \pm 1.0\% \pm 150 \text{ ppm}/^\circ\text{C} \times 100^\circ\text{C}$

E-grade: $\pm 4.5\% = \pm 2.0\% \pm 150 \text{ ppm}/^\circ\text{C} \times 100^\circ\text{C}$

Therefore, as an example, the A-grade LM4041-1.2 has an over-temperature Reverse Breakdown Voltage tolerance of $\pm 1.2\text{V} \times 0.75\% = \pm 9.2 \text{ mV}$.

Note 7: When $V_{OUT} \leq 1.6\text{V}$, the LM4041-ADJ in the SOT-23 package must operate at reduced I_R . This is caused by the series resistance of the die attach between the die (-) output and the package (-) output pin. See the Output Saturation (SOT-23 only) curve in the Typical Performance Characteristics section.

Note 8: Reference voltage and temperature coefficient will change with output voltage. See Typical Performance Characteristics curves.

Typical Performance Characteristics

Temperature Drift for Different Average Temperature Coefficient

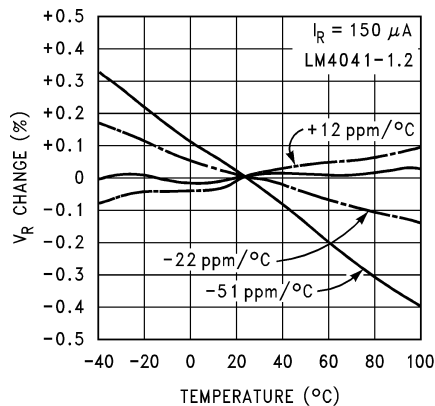

Output Impedance vs Frequency

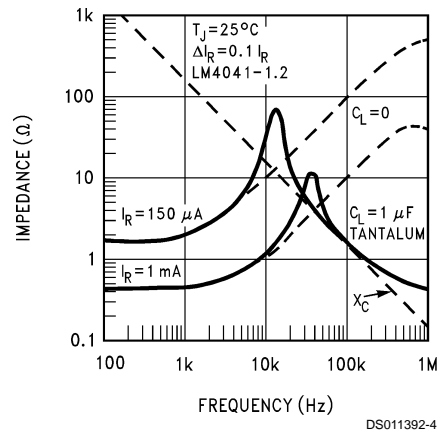

Typical Performance Characteristics (Continued)

Noise Voltage

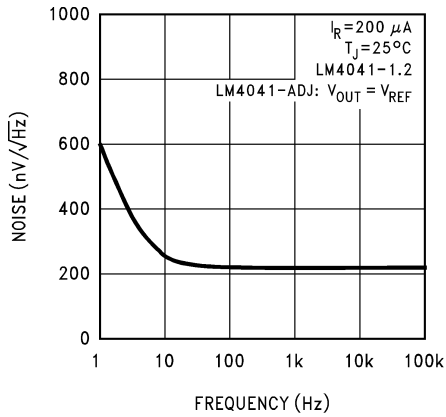

Reverse Characteristics and Minimum Operating Current

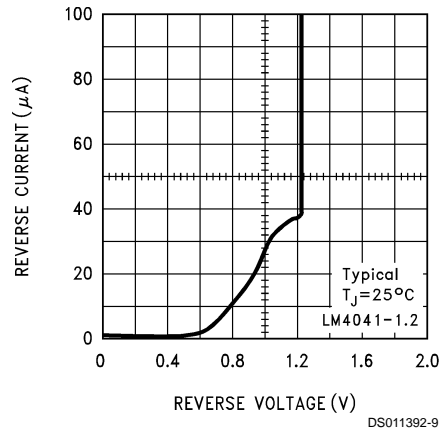

Start-Up Characteristics

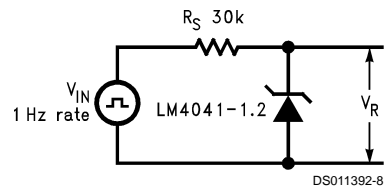
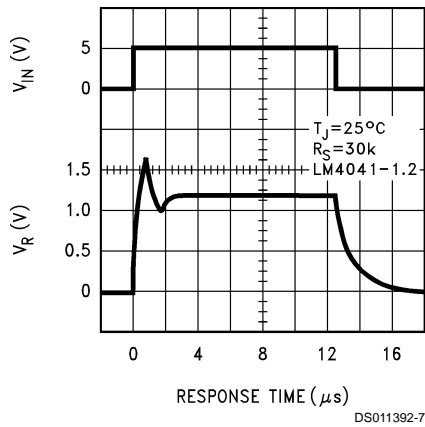

Reference Voltage vs Output Voltage and Temperature

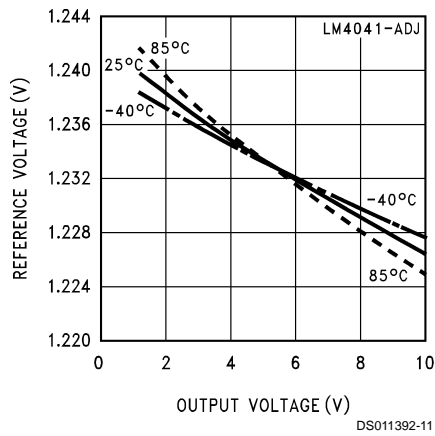

Reference Voltage vs Temperature and Output Voltage

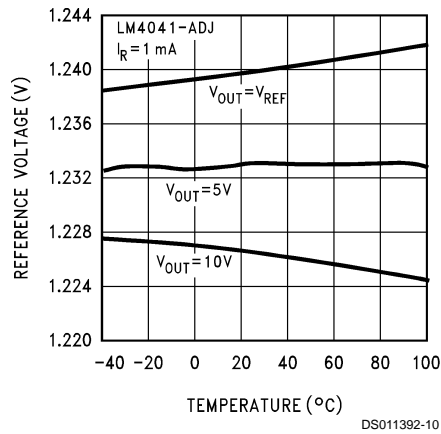

Typical Performance Characteristics (Continued)

Feedback Current vs Output Voltage and Temperature

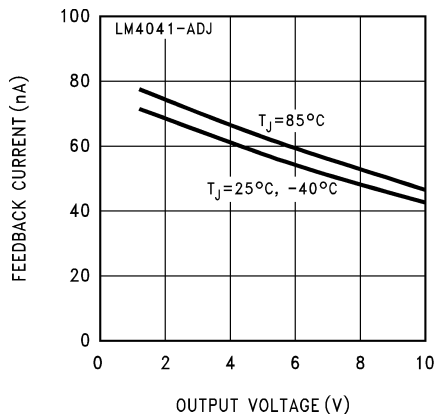

DS011392-12

Output Saturation (SOT-23 Only)

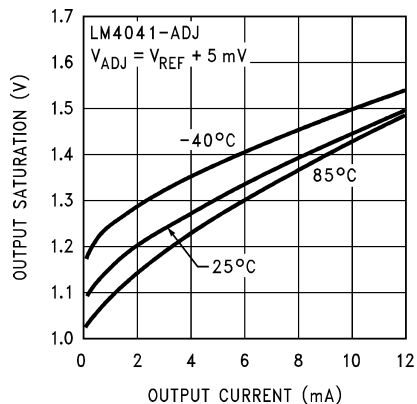

DS011392-33

Output Impedance vs Frequency

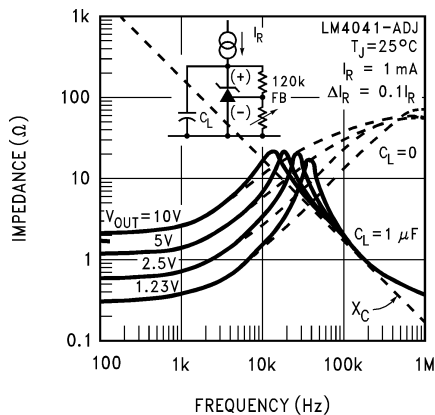

DS011392-13

Output Impedance vs Frequency

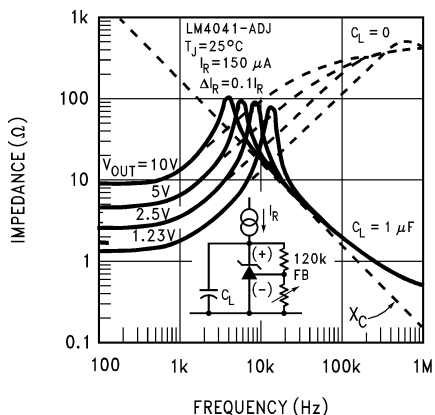

DS011392-14

Reverse Characteristics

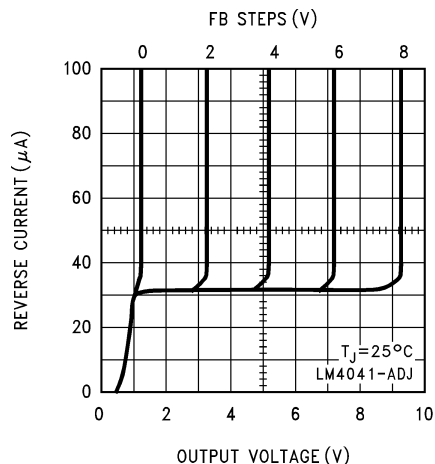

DS011392-15

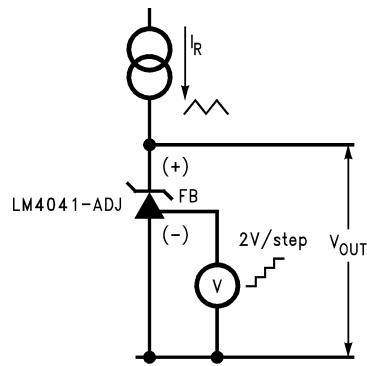

DS011392-16

Typical Performance Characteristics (Continued)

Large Signal Response

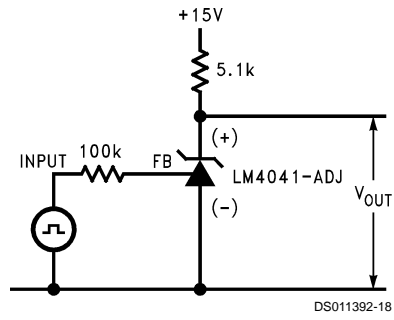
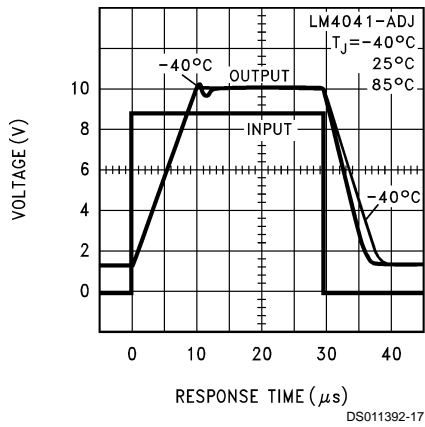

Functional Block Diagram

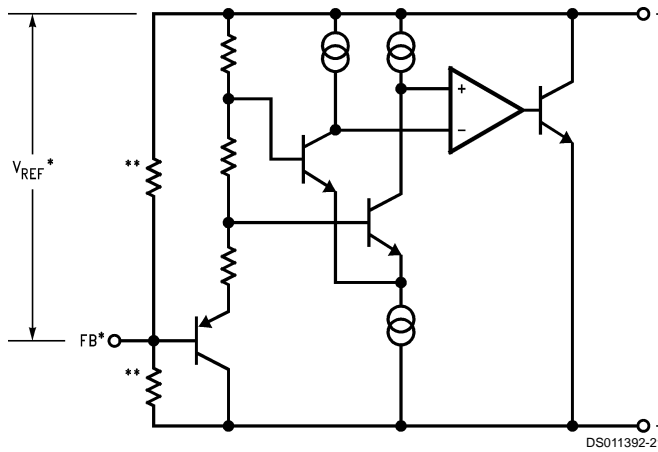

*LM4041-ADJ only
 **LM4041-1.2 only

Applications Information

The LM4041 is a precision micro-power curvature-corrected bandgap shunt voltage reference. For space critical applications, the LM4041 is available in the sub-miniature SOT-23 and SC70 surface-mount package. The LM4041 has been designed for stable operation without the need of an external capacitor connected between the “+” pin and the “-” pin. If, however, a bypass capacitor is used, the LM4041 remains stable. Design effort is further reduced with the choice of either a fixed 1.2V or an adjustable reverse breakdown voltage. The minimum operating current is 60 μ A for the LM4041-1.2 and the LM4041-ADJ. Both versions have a maximum operating current of 12 mA.

LM4041s using the SOT-23 package have pin 3 connected as the (-) output through the package’s die attach interface. Therefore, the LM4041-1.2’s pin 3 must be left floating or connected to pin 2 and the LM4041-ADJ’s pin 3 is the (-) output.

LM4041s using the SC70 package have pin 2 connected as the (-) output through the packages’ die attach interface. Therefore, the LM4041-1.2’s pin 2 must be left floating or connected to pin 1, and the LM4041-ADJ’s pin 2 is the (-) output.

In a conventional shunt regulator application (*Figure 1*), an external series resistor (R_S) is connected between the supply voltage and the LM4041. R_S determines the current that flows through the load (I_L) and the LM4041 (I_Q). Since load current and supply voltage may vary, R_S should be small enough to supply at least the minimum acceptable I_Q to the LM4041 even when the supply voltage is at its minimum and the load current is at its maximum value. When the supply voltage is at its maximum and I_L is at its minimum, R_S should be large enough so that the current flowing through the LM4041 is less than 12 mA.

R_S should be selected based on the supply voltage, (V_S), the desired load and operating current, (I_L and I_Q), and the LM4041’s reverse breakdown voltage, V_R .

$$R_S = \frac{V_S - V_R}{I_L + I_Q}$$

The LM4041-ADJ’s output voltage can be adjusted to any value in the range of 1.24V through 10V. It is a function of the internal reference voltage (V_{REF}) and the ratio of the external feedback resistors as shown in *Figure 2*. The output voltage is found using the equation

$$V_O = V_{REF}[(R_2/R_1) + 1] \quad (1)$$

where V_O is the output voltage. The actual value of the internal V_{REF} is a function of V_O . The “corrected” V_{REF} is determined by

$$V_{REF} = \Delta V_O (\Delta V_{REF}/\Delta V_O) + V_Y \quad (2)$$

where

$$V_Y = 1.240 \text{ V and}$$

$$\Delta V_O = (V_O - V_Y)$$

$\Delta V_{REF}/\Delta V_O$ is found in the Electrical Characteristics and is typically -1.55 mV/V . You can get a more accurate indication of the output voltage by replacing the value of V_{REF} in equation (2) with the value found using equation (2).

Note that the actual output voltage can deviate from that predicted using the typical value of $\Delta V_{REF}/\Delta V_O$ in equation (2): for C-grade parts, the worst-case $\Delta V_{REF}/\Delta V_O$ is -2.5 mV/V . For D-grade parts, the worst-case $\Delta V_{REF}/\Delta V_O$ is -3.0 mV/V .

Typical Applications

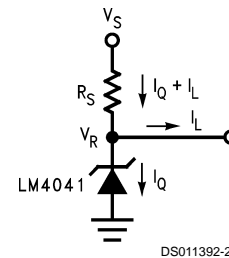
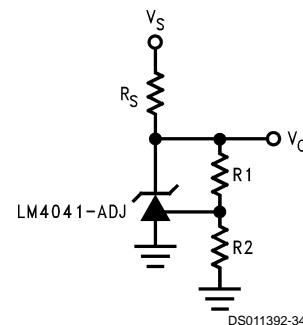

FIGURE 1. Shunt Regulator



$$V_O = V_{REF}[(R_2/R_1) + 1]$$

FIGURE 2. Adjustable Shunt Regulator

Typical Applications (Continued)

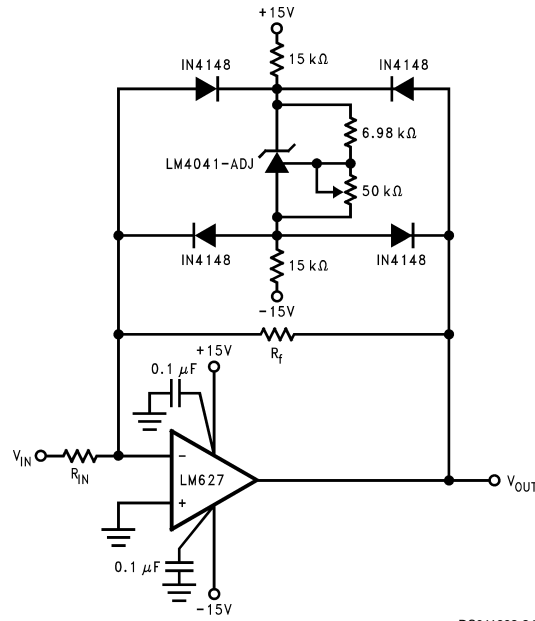

DS011392-24

FIGURE 3. Bounded amplifier reduces saturation-induced delays and can prevent succeeding stage damage. Nominal clamping voltage is $\pm V_O$ (LM4041's reverse breakdown voltage) +2 diode V_F .

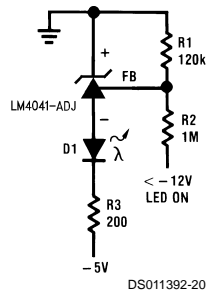

DS011392-20

FIGURE 4. Voltage Level Detector

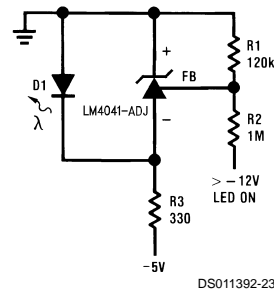

DS011392-23

FIGURE 5. Voltage Level Detector

Typical Applications (Continued)

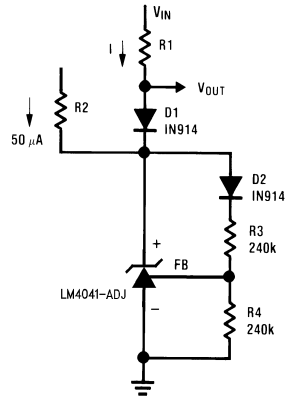

FIGURE 6. Fast Positive Clamp
 $2.4V + V_{D1}$

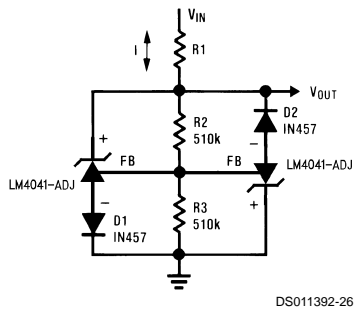

FIGURE 7. Bidirectional Clamp $\pm 2.4V$

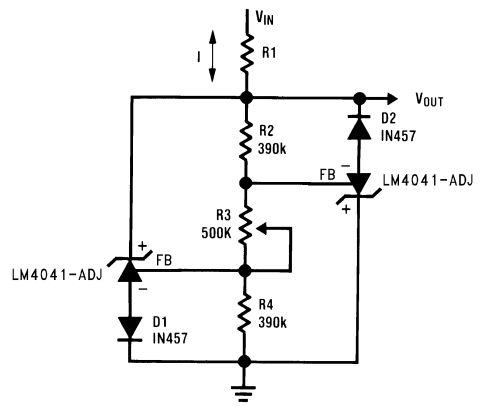

FIGURE 8. Bidirectional Adjustable Clamp $\pm 18V$ to $\pm 2.4V$

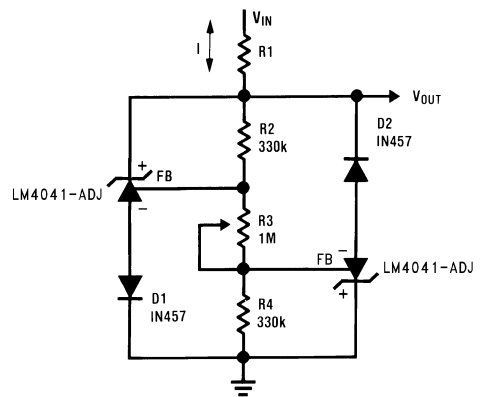
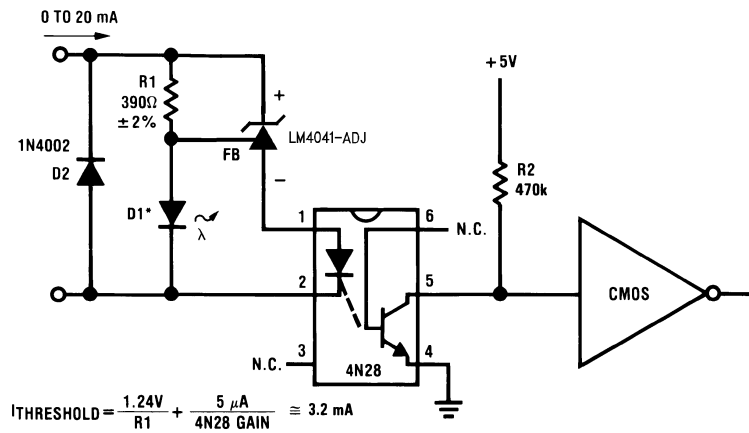

FIGURE 9. Bidirectional Adjustable Clamp $\pm 2.4V$ to $\pm 6V$



$$I_{THRESHOLD} = \frac{1.24V}{R1} + \frac{5 \mu A}{4N28 \text{ GAIN}} \cong 3.2 \text{ mA}$$

FIGURE 10. Simple Floating Current Detector

Typical Applications (Continued)

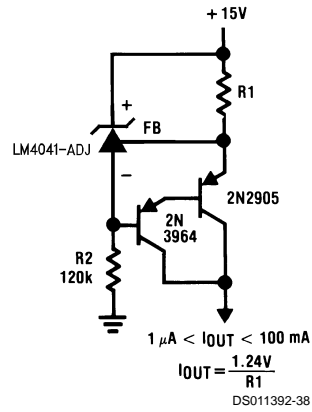

FIGURE 11. Current Source

Note 9: *D1 can be any LED, $V_F = 1.5V$ to $2.2V$ at $3 mA$. D1 may act as an indicator. D1 will be on if $I_{THRESHOLD}$ falls below the threshold current, except with $I = 0$.

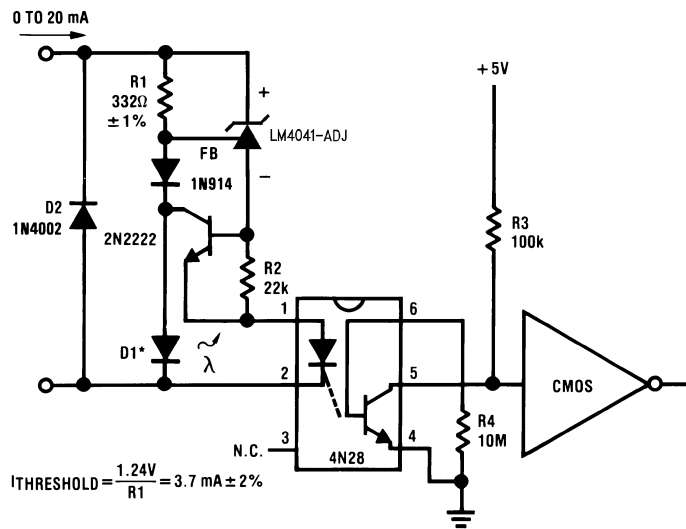
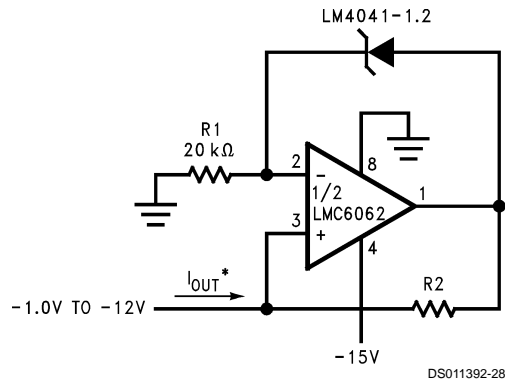

FIGURE 12. Precision Floating Current Detector

Typical Applications (Continued)



$$*I_{OUT} = \frac{1.2V}{R2}$$

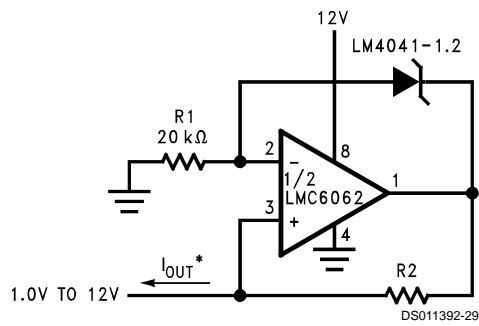
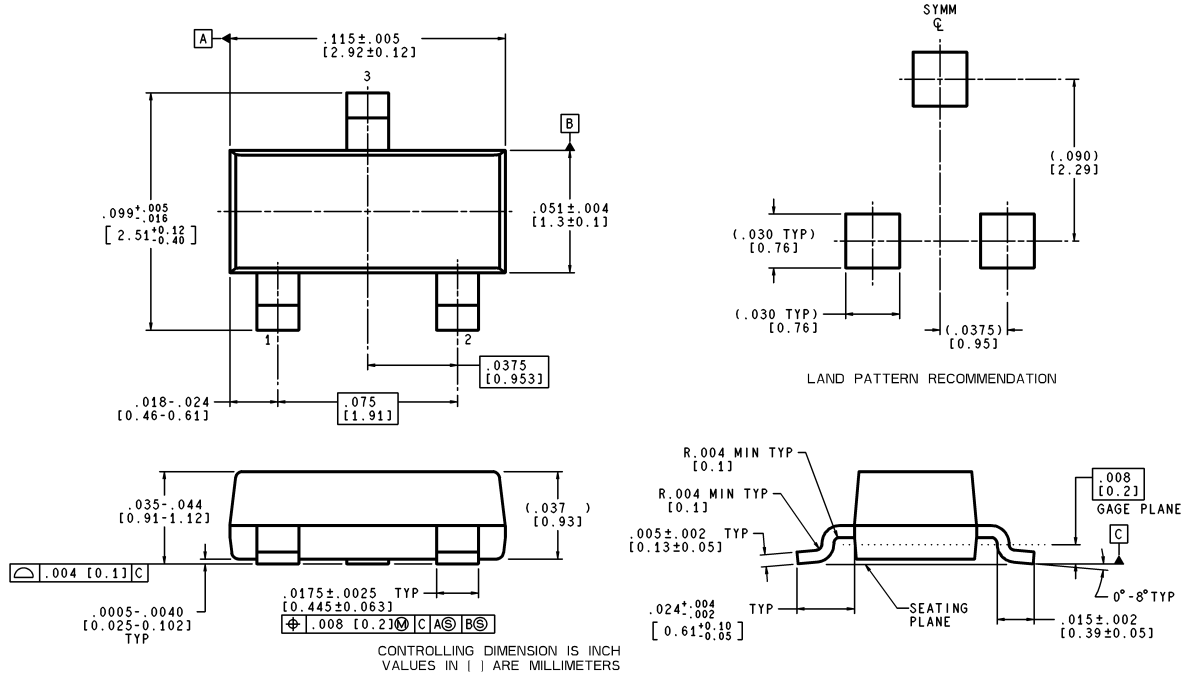

FIGURE 13. Precision 1 μ A to 1 mA Current Sources

Physical Dimensions inches (millimeters) unless otherwise noted



**Plastic Surface Mount Package (M3)
NS Package Number MF03A
(JEDEC Registration TO-236AB)**

MF03A (Rev A)

Physical Dimensions inches (millimeters) unless otherwise noted (Continued)

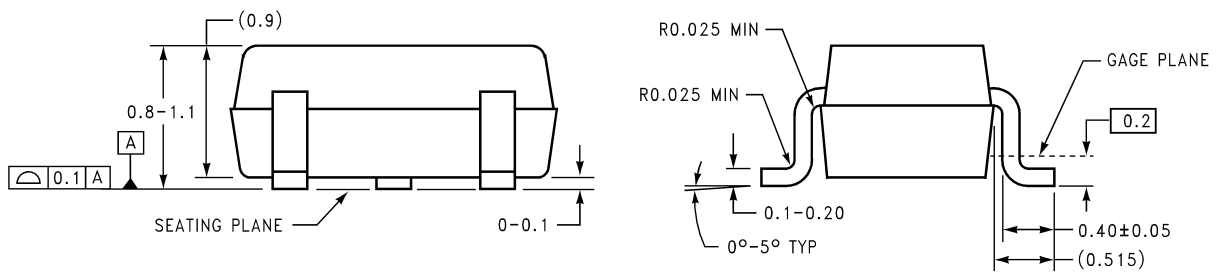
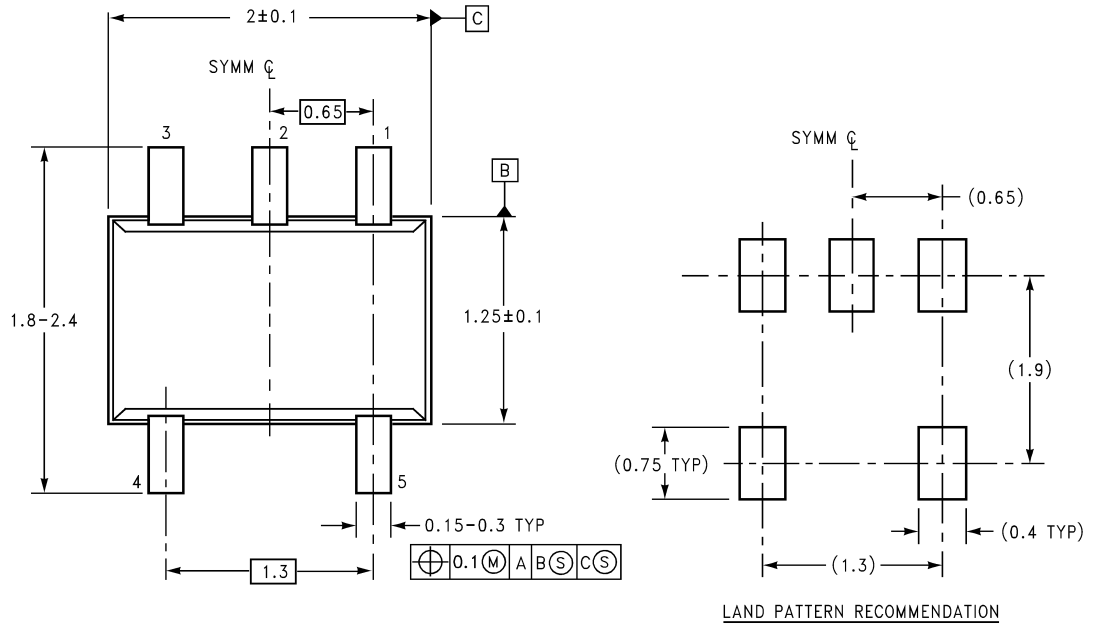

DIMENSIONS ARE IN MILLIMETERS

MAA05A (REV B)

Molded Package (SC70)
NS Package Number MAA05A

Physical Dimensions inches (millimeters) unless otherwise noted (Continued)

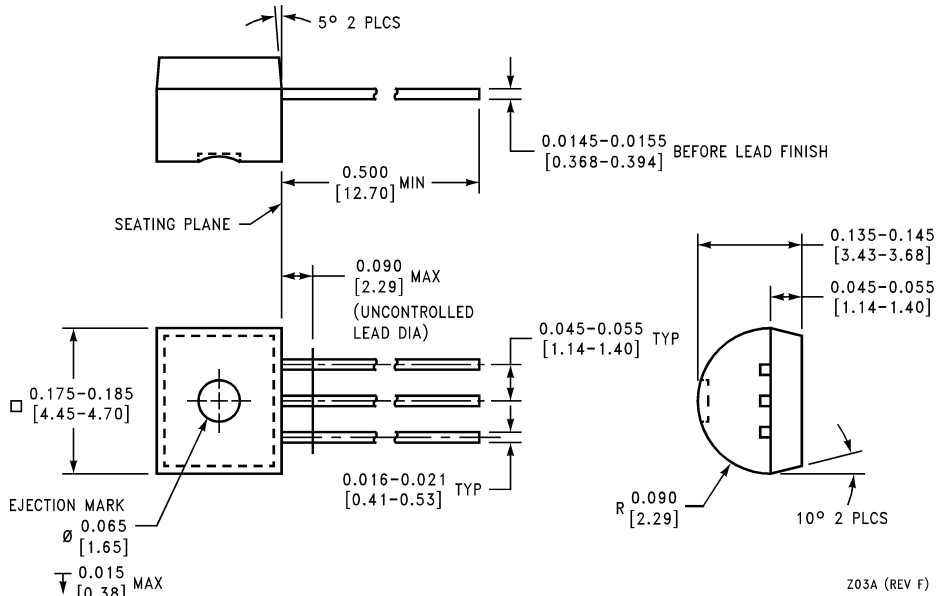

**Plastic Package (Z)
NS Package Number Z03A**

Z03A (REV F)

LIFE SUPPORT POLICY

NATIONAL'S PRODUCTS ARE NOT AUTHORIZED FOR USE AS CRITICAL COMPONENTS IN LIFE SUPPORT DEVICES OR SYSTEMS WITHOUT THE EXPRESS WRITTEN APPROVAL OF THE PRESIDENT AND GENERAL COUNSEL OF NATIONAL SEMICONDUCTOR CORPORATION. As used herein:

1. Life support devices or systems are devices or systems which, (a) are intended for surgical implant into the body, or (b) support or sustain life, and whose failure to perform when properly used in accordance with instructions for use provided in the labeling, can be reasonably expected to result in a significant injury to the user.
2. A critical component is any component of a life support device or system whose failure to perform can be reasonably expected to cause the failure of the life support device or system, or to affect its safety or effectiveness.



National Semiconductor Corporation
Americas
Tel: 1-800-272-9959
Fax: 1-800-737-7018
Email: support@nsc.com
www.national.com

National Semiconductor Europe
Fax: +49 (0) 180-530 85 86
Email: europe.support@nsc.com
Deutsch Tel: +49 (0) 69 9508 6208
English Tel: +44 (0) 870 24 0 2171
Français Tel: +33 (0) 1 41 91 8790

National Semiconductor Asia Pacific Customer Response Group
Tel: 65-2544466
Fax: 65-2504466
Email: ap.support@nsc.com

National Semiconductor Japan Ltd.
Tel: 81-3-5639-7560
Fax: 81-3-5639-7507