

ULTRALOW-POWER SC70/SOT-323 PACKAGED 10 mA LDO LINEAR REGULATORS WITH POWER GOOD OUTPUT

FEATURES

- 10-mA Low-Dropout Regulator
- Ultralow 1.2- μ A Quiescent Current at 10 mA
- 5-Pin SC70/SOT-323 (DCK) Package
- Integrated Power Good Output
- Stable With Any Capacitor ($>0.47 \mu$ F)
- Dropout Voltage Typically 105 mV at 10 mA (TPS79733)
- Over Current Limitation
- -40°C to 85°C Operating Junction Temperature Range

APPLICATIONS

- Battery Powered Microcontrollers and Microprocessors

DESCRIPTION

The TPS797xx family of low-dropout (LDO) voltage regulators offers the benefits of low-dropout voltage and ultralow-power operation. The device is stable with any capacitor ($>0.47 \mu$ F). Therefore, implementations of this device require very little board space due to the miniaturized packaging and potentially small output capacitor. In addition, the family includes an integrated open drain active-high power good (PG) output. Intended for use in microcontroller based, battery-powered applications, the TPS797xx family's low dropout and ultralow-powered operation results in a significant increase in system battery operating life. The small packaging minimizes consumption of board space.

The device is enabled when the applied voltage exceeds the minimum input voltage. The usual PNP pass transistor has been replaced by a PMOS pass

element. Because the PMOS pass element behaves as a low-value resistor, the dropout voltage is very low, typically 105 mV at 10 mA of load current, and is directly proportional to the load current. The quiescent current is ultralow (1.2 μ A typically) and is stable over the entire range of output load current (0 mA to 10 mA). When properly configured with a pullup resistor, the PG output can be used to implement a power-on reset or low battery indicator. The TPS797xx is offered in 1.8-V, 3-V, 3.3-V fixed options.

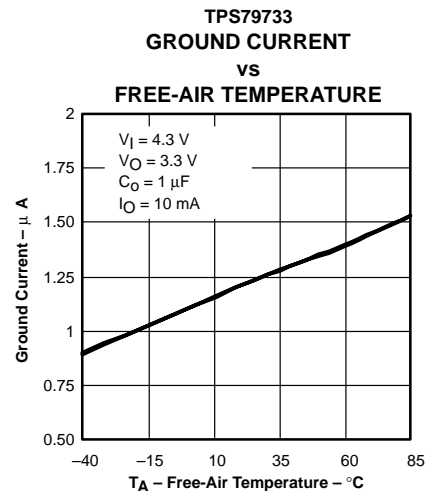
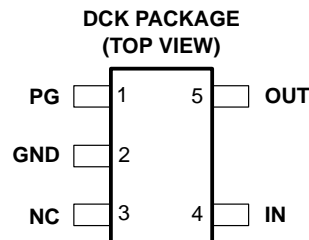

Please be aware that an important notice concerning availability, standard warranty, and use in critical applications of Texas Instruments semiconductor products and disclaimers thereto appears at the end of this data sheet.

AVAILABLE OPTIONS†

T _A	VOLTAGE	PACKAGE	PART NUMBER		SYMBOL
-40°C to 85°C	1.8 V	SC70/SOT-323 (DCK)	TPS79718DCKT‡	TPS79718DCKR§	ATD
	3 V		TPS79730DCKT‡	TPS79730DCKR§	ATE
	3.3 V		TPS79733DCKT‡	TPS79733DCKR§	ATF

† Contact the factory for the availability of other voltage options between 1.25 V and 4.9 V.

‡ The DCKT indicates tape and reel of 250 parts.

§ The DCKR indicates tape and reel of 3000 parts.

absolute maximum ratings over operating free-air temperature range (unless otherwise noted)¶

Input voltage range (see Note 1)	-0.3 V to 6 V
Maximum dc output voltage	4.9 V
Peak output current	Internally limited
ESD rating, HBM	2 kV
ESD rating, CDM	500 V
Continuous total power dissipation	See Dissipation Rating Table
Operating junction temperature range, T _J	-40°C to 85°C
Operating ambient temperature range, T _A	-40°C to 85°C
Storage temperature range, T _{stg}	-65°C to 150°C

¶ Stresses beyond those listed under “absolute maximum ratings” may cause permanent damage to the device. These are stress ratings only, and functional operation of the device at these or any other conditions beyond those indicated under “recommended operating conditions” is not implied. Exposure to absolute-maximum-rated conditions for extended periods may affect device reliability.

NOTE 1: All voltage values are with respect to network ground terminal.

DISSIPATION RATING TABLE

BOARD	PACKAGE	R _{θJC} °C/W	R _{θJA} °C/W	DERATING FACTOR ABOVE T _A = 25°C	T _A ≤ 25°C	T _A = 70°C	T _A = 85°C
					POWER RATING	POWER RATING	POWER RATING
Low k [#]	DCK	165.39	396.24	2.52 mW/°C	252mW	139 mW	101 mW
High K	DCK	165.39	314.74	3.18 mW/°C	318 mW	175 mW	127 mW

[#] The JEDEC Low K (1s) board design used to derive this data was a 3 inch x 3 inch, two layer board with 2 ounce copper traces on top of the board.

^{||} The JEDEC High K (2s2p) board design used to derive this data was a 3 inch x 3 inch, multilayer board with 1 ounce internal power and ground planes and 2 ounce copper traces on top and bottom of the board.

**electrical characteristics over recommended operating free-air temperature range,
 $V_I = V_O(\text{typ}) + 1 \text{ V}$, $I_O = 1 \text{ mA}$, $C_O = 1 \mu\text{F}$ (unless otherwise noted)**

PARAMETER		TEST CONDITIONS		MIN	TYP	MAX	UNIT
V_I	Input voltage (see Note 2)	$I_O = 3 \text{ mA}$		1.8		5.5	V
		$I_O = 10 \text{ mA}$		2		5.5	V
I_O	Continuous output current (see Note 3)			0		10	mA
T_J	Operating junction temperature, T_J			-40		85	°C
Output voltage (10 μA to 10 mA Load) (see Note 4)	TPS79718	$T_A = 25^\circ\text{C}$, $2.8 \text{ V} < V_I < 5.5 \text{ V}$		1.8			V
		$T_A = -40^\circ\text{C}$ to 85°C , $2.8 \text{ V} < V_I < 5.5 \text{ V}$		1.728		1.872	
	TPS79730	$T_A = 25^\circ\text{C}$, $4 \text{ V} < V_I < 5.5 \text{ V}$		3.0			V
		$T_A = -40^\circ\text{C}$ to 85°C , $4 \text{ V} < V_I < 5.5 \text{ V}$		2.880		3.120	
	TPS79733	$T_A = 25^\circ\text{C}$, $4.3 \text{ V} < V_I < 5.5 \text{ V}$		3.3			V
		$T_A = -40^\circ\text{C}$ to 85°C , $4.3 \text{ V} < V_I < 5.5 \text{ V}$		3.168		3.432	
Quiescent current (GND current) (see Note 4)	$T_A = 25^\circ\text{C}$, $0 \mu\text{A} < I_O < 10 \text{ mA}$		1.2			μA	
	$T_A = -40^\circ\text{C}$ to 85°C , $I_O = 10 \text{ mA}$				2		
Load regulation	$T_A = 25^\circ\text{C}$, $I_O = 1 \mu\text{A}$ to 10 mA		17			mV	
Output voltage line regulation ($\Delta V_O/V_O$) (see Note 4)	$V_O + 1 \text{ V} < V_I \leq 5.5 \text{ V}$, $T_A = 25^\circ\text{C}$		0.15			%V	
	$V_O + 1 \text{ V} < V_I \leq 5.5 \text{ V}$, $T_A = -40^\circ\text{C}$ to 85°C				0.8		
Output noise voltage (TPS79718)	BW = 200 Hz to 100 kHz, $C_O = 10 \mu\text{F}$, $I_O = 10 \text{ mA}$, $T_A = 25^\circ\text{C}$		600			μV_{RMS}	
Output current limit	$V_O = 0 \text{ V}$, See Note 4		190		300	mA	
Power supply ripple rejection (TPS79718)	$f = 100 \text{ Hz}$, $C_O = 10 \mu\text{F}$, $I_O = 10 \text{ mA}$, $T_A = 25^\circ\text{C}$		50			dB	
Dropout voltage (see Note 5)	TPS79730	$I_O = 10 \text{ mA}$, $T_A = 25^\circ\text{C}$		110		mV	
		$I_O = 10 \text{ mA}$, $T_A = -40^\circ\text{C}$ to 85°C		200			
	TPS79733	$I_O = 10 \text{ mA}$, $T_A = 25^\circ\text{C}$		105			
		$I_O = 10 \text{ mA}$, $T_A = -40^\circ\text{C}$ to 85°C		200			
Minimum input voltage for valid PG	$I_O(\text{PG}) = 100 \mu\text{A}$, $V(\text{PG}) \geq 0.8 \text{ V}$		1.2			V	
PG trip threshold voltage	V_O decreasing		82	90	96	% V_O	
PG output low voltage	$V_I = 1.5 \text{ V}$, $I_O(\text{PG}) = 1 \text{ mA}$		0.14		0.225	V	
PG leakage current	$V(\text{PG}) = 5 \text{ V}$		0.1			nA	

- NOTES: 2. To calculate the minimum input voltage for your maximum output current, use the following formula:
 $V_I(\text{min}) = V_O(\text{max}) + V_{\text{DO}}(\text{max load})$
3. Continuous output current is limited by internal protection circuitry, but it is not recommended that the device operate under conditions beyond those specified in this table for extended periods of time.
4. The minimum IN operating voltage is 1.8 V or $V_O(\text{typ}) + 1 \text{ V}$, whichever is greater. The maximum IN voltage is 5.5 V. There is no minimum output current requirement and the maximum output current is 10 mA.
5. IN voltage equals $V_O(\text{typ}) - 100 \text{ mV}$; The TPS79730 input voltage is set to 2.9 V and the TPS79733 input voltage is set to 3.2 V. The TPS79718 dropout voltage is limited by input voltage range limitations.

functional block diagram

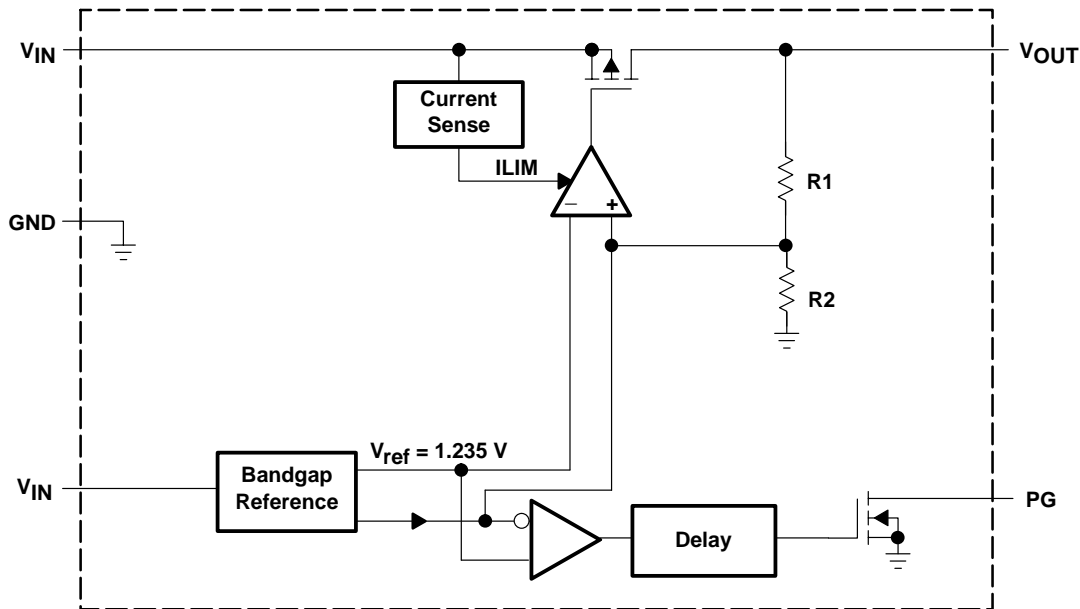

Terminal Functions

TERMINAL NAME	NO.	I/O	DESCRIPTION
GND	2		Ground
NC	3		No connection
OUT	5	O	The OUT terminal provides the regulated output voltage of the device.
PG	1	O	The PG terminal for the fixed voltage option devices is an open drain, active-high output that indicates the status of V_O (output of the LDO). When V_O exceeds approximately 90% of the regulated voltage, PG goes to a high impedance state. It goes to a low-impedance state when V_O falls below approximately 90% (i.e. overload condition) of the regulated voltage. The open drain output of the PG terminal requires a pullup resistor.
IN	4	I	The IN terminal is the power supply input to the device.

TPS797xx PG timing diagram

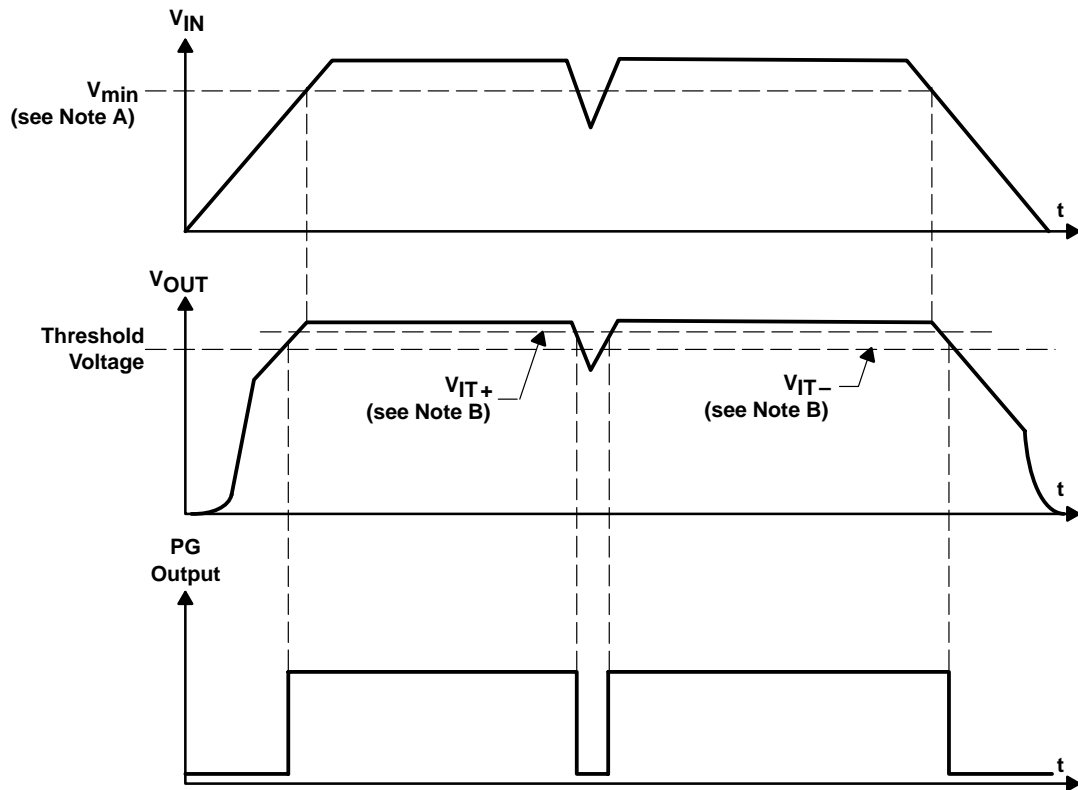

- NOTES: A. $V_{min} = V_{OUT} + V_{DO}$
 B. The PG trip voltage is typically 10% lower than the output voltage ($90\%V_O$). V_{IT-} to V_{IT+} is the hysteresis voltage.

TYPICAL CHARACTERISTICS

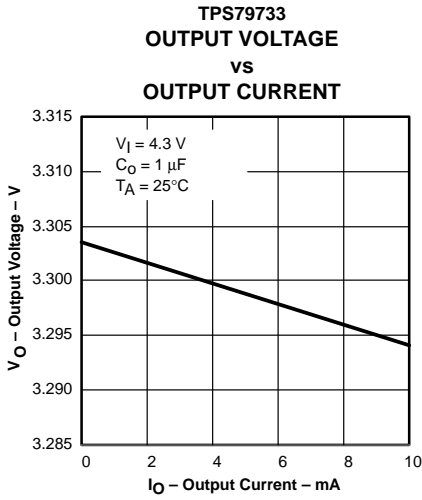

Figure 1

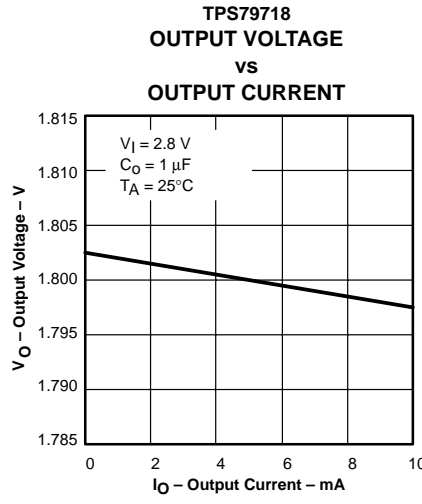

Figure 2

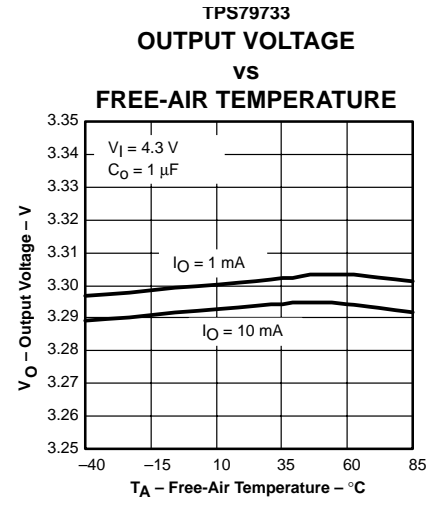

Figure 3

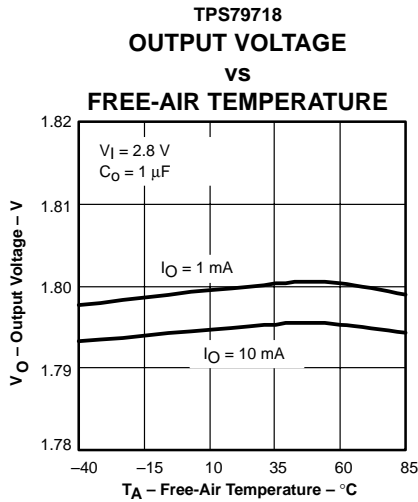

Figure 4

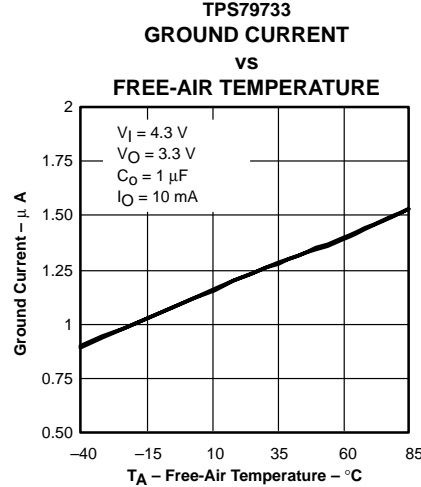

Figure 5

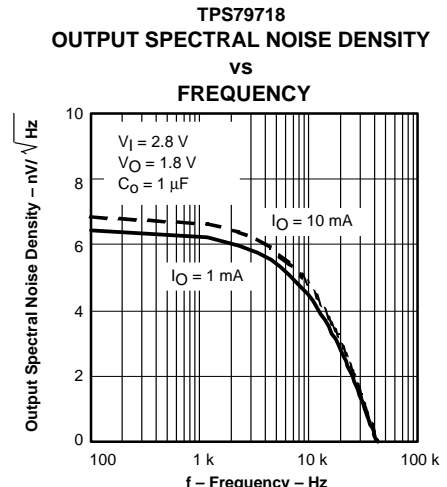

Figure 6

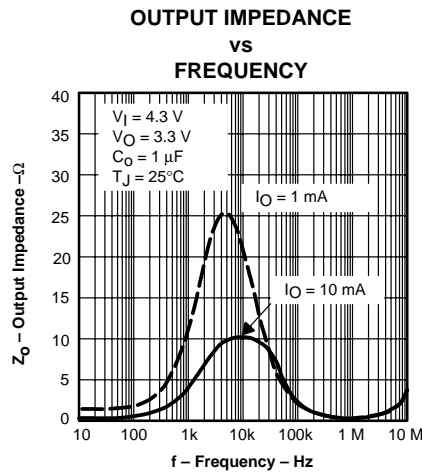

Figure 7

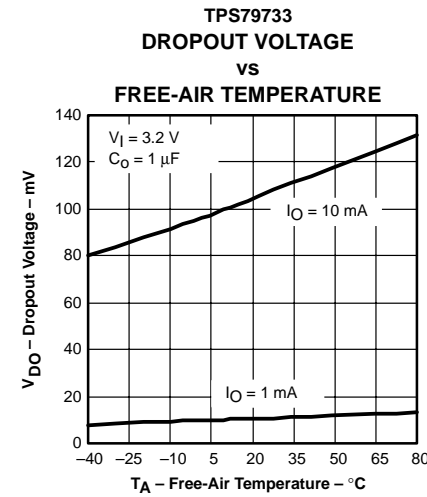

Figure 8

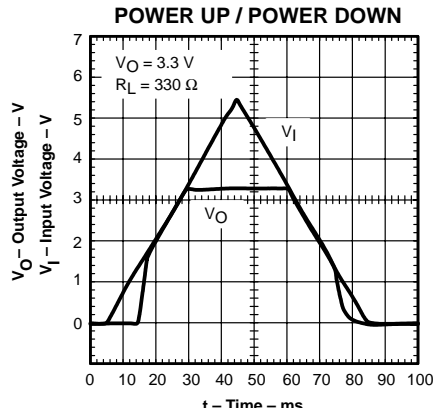
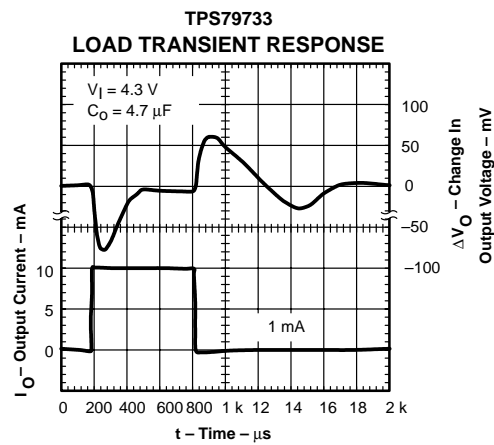
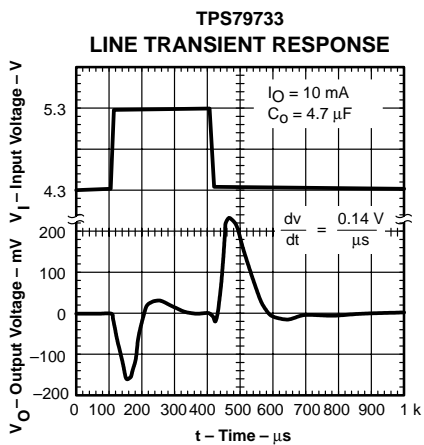
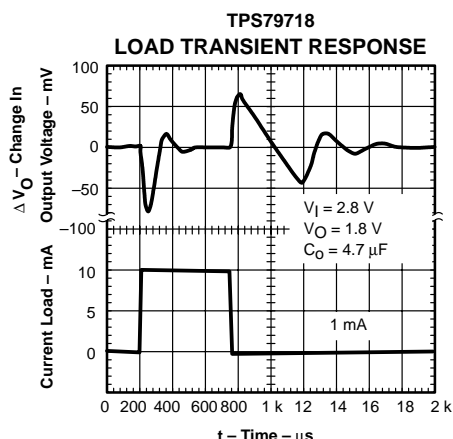
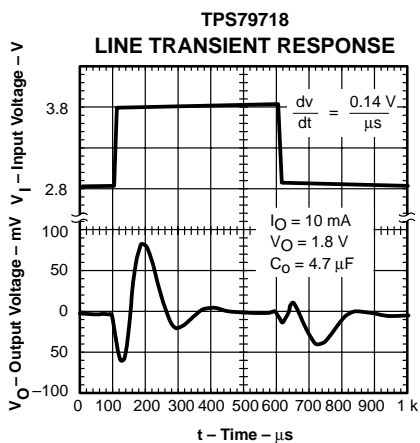

Figure 9

TYPICAL CHARACTERISTICS



APPLICATION INFORMATION

The TPS797xx family of low-dropout (LDO) regulators have been optimized for use in micropower applications. They feature extremely low dropout voltages, and ultralow quiescent current (1.2 μA typically).

A typical application circuit is shown in Figure 16.

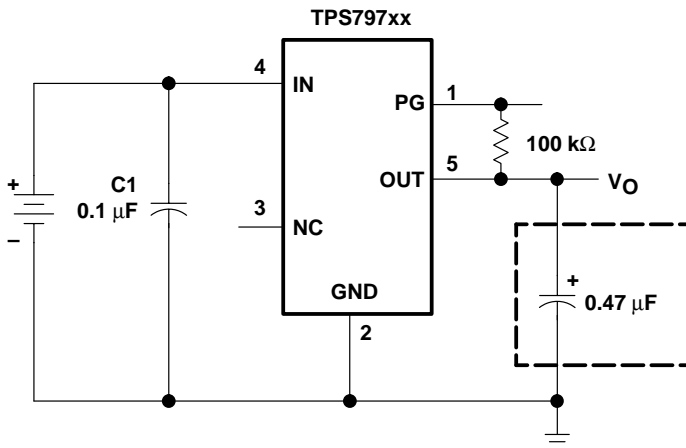

Figure 14. Typical Application Circuit

external capacitor requirements

Although not required, a 0.1- μF or larger input bypass capacitor, connected between IN and GND and located close to the TPS797xx, is recommended, especially when a highly resistive power supply is powering the LDO in addition to other devices.

Like all low-dropout regulators, the TPS797xx requires an output capacitor connected between OUT and GND to stabilize the internal control loop. The minimum recommended capacitance is 0.47 μF . Any 0.47- μF capacitor is suitable. Capacitor values larger than 0.47 μF are acceptable.

APPLICATION INFORMATION

power dissipation and junction temperature

Specified regulator operation is assured to a junction temperature of 85°C; restrict the maximum junction temperature to 85°C under normal operating conditions. This restriction limits the power dissipation the regulator can handle in any given application. To ensure the junction temperature is within acceptable limits, calculate the maximum allowable dissipation, $P_{D(max)}$, and the actual dissipation, P_D , which must be less than or equal to $P_{D(max)}$.

The maximum-power-dissipation limit is determined using the following equation:

$$P_{D(max)} = \frac{T_{Jmax} - T_A}{R_{\theta JA}}$$

Where:

T_{Jmax} is the maximum allowable junction temperature.

$R_{\theta JA}$ is the thermal resistance junction-to-ambient for the package (see Power Dissipation Rating Table).

T_A is the ambient temperature.

The regulator dissipation is calculated using:

$$P_D = (V_I - V_O) \times I_O$$

Power dissipation resulting from quiescent current is negligible. Excessive power dissipation triggers the thermal protection circuit.

regulator protection

The TPS797xx PMOS-pass transistor has a built-in back diode that conducts reverse current when the input voltage drops below the output voltage (e.g., during power down). Current is conducted from the output to the input and is not internally limited. If extended reverse voltage operation is anticipated, external limiting might be appropriate.

The TPS797xx features internal current limiting. During normal operation, the TPS797xx limits output current to approximately 190 mA. When current limiting engages, the output voltage scales back linearly until the overcurrent condition ends. Take care not to exceed the power dissipation ratings of the package.

microcontroller application

One application for which this device is particularly suited is providing a regulated input voltage and power good (PG) supervisory signal to low-power devices such as mixed-signal microcontrollers. The quiescent or ground current of the TPS797xx family is typically 1.2 μ A even at full load; therefore, the reduction in battery life by including the TPS797xx in the system is negligible. The primary benefits of using the TPS797xx to power low power digital devices include:

- Regulated output voltage that protects the device from battery droop and noise on the line (e.g., switch bounce)
- Smooth, monotonic power up
- PG signal for controlled device RESET
- Potential to use an existing 5-V power rail to power a 3.3-V or lower device
- Potential to provide separate digital and analog power and ground supplies for a system with only one power source

APPLICATION INFORMATION

microcontroller application (continued)

Figure 17 shows an application in which the TPS79718 is used to power TI's MSP430 mixed signal microcontroller.

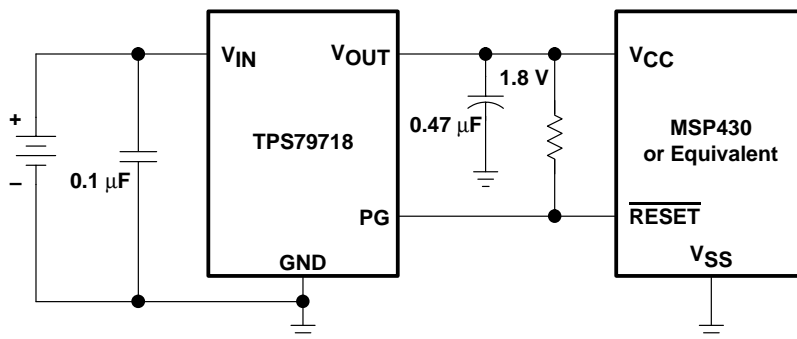

Figure 15. MSP430 Microcontroller Powered by the TPS79718 Regulator

Minimal board space is needed to accommodate the DCK (SC70/SOT-323) packaged TPS79718, the 0.1-μF output capacitor, the 0.47-μF input capacitor, and the pullup resistor on the PG pin.

MECHANICAL DATA

DCK (R-PDSO-G5)

PLASTIC SMALL-OUTLINE

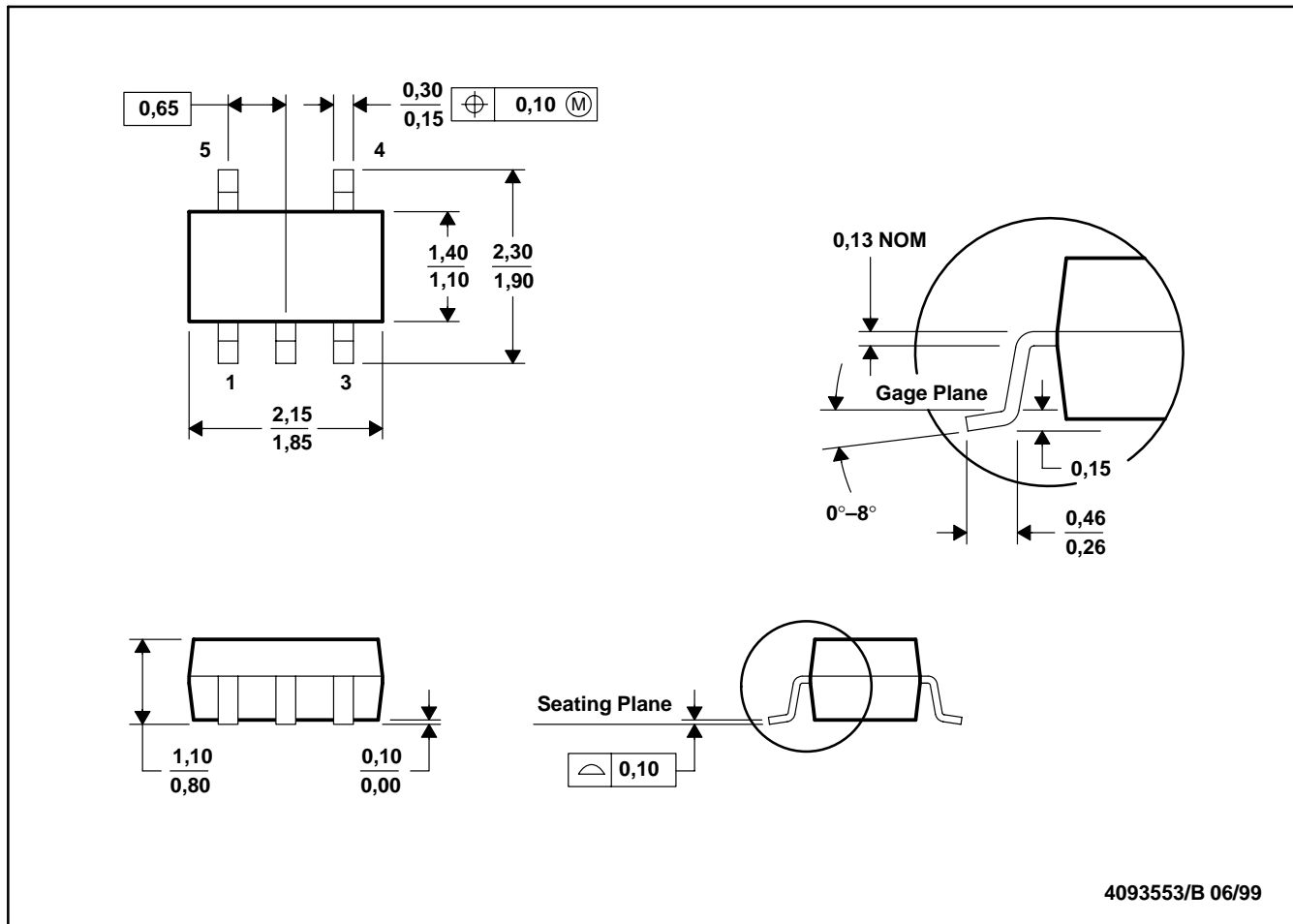

- NOTES:
- A. All linear dimensions are in millimeters.
 - B. This drawing is subject to change without notice.
 - C. Body dimensions do not include mold flash or protrusion.
 - D. Falls within JEDEC MO-203

PACKAGING INFORMATION

Orderable Device	Status ⁽¹⁾	Package Type	Package Drawing	Pins	Package Qty	Eco Plan ⁽²⁾	Lead/Ball Finish	MSL Peak Temp ⁽³⁾
TPS79718DCKR	ACTIVE	SC70	DCK	5	3000	Green (RoHS & no Sb/Br)	CU NIPDAU	Level-1-260C-UNLIM
TPS79718DCKT	ACTIVE	SC70	DCK	5	250	Green (RoHS & no Sb/Br)	CU NIPDAU	Level-1-260C-UNLIM
TPS79730DCKR	ACTIVE	SC70	DCK	5	3000	Green (RoHS & no Sb/Br)	CU NIPDAU	Level-1-260C-UNLIM
TPS79730DCKT	ACTIVE	SC70	DCK	5	250	Green (RoHS & no Sb/Br)	CU NIPDAU	Level-1-260C-UNLIM
TPS79733DCKR	ACTIVE	SC70	DCK	5	3000	Green (RoHS & no Sb/Br)	CU NIPDAU	Level-1-260C-UNLIM
TPS79733DCKT	ACTIVE	SC70	DCK	5	250	Green (RoHS & no Sb/Br)	CU NIPDAU	Level-1-260C-UNLIM

⁽¹⁾ The marketing status values are defined as follows:

ACTIVE: Product device recommended for new designs.

LIFEBUY: TI has announced that the device will be discontinued, and a lifetime-buy period is in effect.

NRND: Not recommended for new designs. Device is in production to support existing customers, but TI does not recommend using this part in a new design.

PREVIEW: Device has been announced but is not in production. Samples may or may not be available.

OBSOLETE: TI has discontinued the production of the device.

⁽²⁾ Eco Plan - May not be currently available - please check <http://www.ti.com/productcontent> for the latest availability information and additional product content details.

None: Not yet available Lead (Pb-Free).

Pb-Free (RoHS): TI's terms "Lead-Free" or "Pb-Free" mean semiconductor products that are compatible with the current RoHS requirements for all 6 substances, including the requirement that lead not exceed 0.1% by weight in homogeneous materials. Where designed to be soldered at high temperatures, TI Pb-Free products are suitable for use in specified lead-free processes.

Green (RoHS & no Sb/Br): TI defines "Green" to mean "Pb-Free" and in addition, uses package materials that do not contain halogens, including bromine (Br) or antimony (Sb) above 0.1% of total product weight.

⁽³⁾ MSL, Peak Temp. -- The Moisture Sensitivity Level rating according to the JEDEC industry standard classifications, and peak solder temperature.

Important Information and Disclaimer: The information provided on this page represents TI's knowledge and belief as of the date that it is provided. TI bases its knowledge and belief on information provided by third parties, and makes no representation or warranty as to the accuracy of such information. Efforts are underway to better integrate information from third parties. TI has taken and continues to take reasonable steps to provide representative and accurate information but may not have conducted destructive testing or chemical analysis on incoming materials and chemicals. TI and TI suppliers consider certain information to be proprietary, and thus CAS numbers and other limited information may not be available for release.

In no event shall TI's liability arising out of such information exceed the total purchase price of the TI part(s) at issue in this document sold by TI to Customer on an annual basis.

IMPORTANT NOTICE

Texas Instruments Incorporated and its subsidiaries (TI) reserve the right to make corrections, modifications, enhancements, improvements, and other changes to its products and services at any time and to discontinue any product or service without notice. Customers should obtain the latest relevant information before placing orders and should verify that such information is current and complete. All products are sold subject to TI's terms and conditions of sale supplied at the time of order acknowledgment.

TI warrants performance of its hardware products to the specifications applicable at the time of sale in accordance with TI's standard warranty. Testing and other quality control techniques are used to the extent TI deems necessary to support this warranty. Except where mandated by government requirements, testing of all parameters of each product is not necessarily performed.

TI assumes no liability for applications assistance or customer product design. Customers are responsible for their products and applications using TI components. To minimize the risks associated with customer products and applications, customers should provide adequate design and operating safeguards.

TI does not warrant or represent that any license, either express or implied, is granted under any TI patent right, copyright, mask work right, or other TI intellectual property right relating to any combination, machine, or process in which TI products or services are used. Information published by TI regarding third-party products or services does not constitute a license from TI to use such products or services or a warranty or endorsement thereof. Use of such information may require a license from a third party under the patents or other intellectual property of the third party, or a license from TI under the patents or other intellectual property of TI.

Reproduction of information in TI data books or data sheets is permissible only if reproduction is without alteration and is accompanied by all associated warranties, conditions, limitations, and notices. Reproduction of this information with alteration is an unfair and deceptive business practice. TI is not responsible or liable for such altered documentation.

Resale of TI products or services with statements different from or beyond the parameters stated by TI for that product or service voids all express and any implied warranties for the associated TI product or service and is an unfair and deceptive business practice. TI is not responsible or liable for any such statements.

Following are URLs where you can obtain information on other Texas Instruments products and application solutions:

Products		Applications	
Amplifiers	amplifier.ti.com	Audio	www.ti.com/audio
Data Converters	dataconverter.ti.com	Automotive	www.ti.com/automotive
DSP	dsp.ti.com	Broadband	www.ti.com/broadband
Interface	interface.ti.com	Digital Control	www.ti.com/digitalcontrol
Logic	logic.ti.com	Military	www.ti.com/military
Power Mgmt	power.ti.com	Optical Networking	www.ti.com/opticalnetwork
Microcontrollers	microcontroller.ti.com	Security	www.ti.com/security
		Telephony	www.ti.com/telephony
		Video & Imaging	www.ti.com/video
		Wireless	www.ti.com/wireless

Mailing Address: Texas Instruments
Post Office Box 655303 Dallas, Texas 75265